

MODIFICATION PROPOSAL FORM

MPID 269 –POWER PARK MODULES

FORM GC1, PROPOSAL OF MODIFICATION TO GRID CODE.



160 SHELBOURNE ROAD
BALLSBRIDGE
DUBLIN 4
PH: +353-1-677 1700
FAX: +353-1-6615375
EMAIL: GRIDCODE@EIRGRID.COM

MODIFICATION PROPOSAL ORIGINATOR:	EIRGRID & SONI		
MODIFICATION PROPOSAL ORIGINATOR (CONTACT NAME)	LISA MCMULLAN	MODIFICATION PROPOSAL ORIGINATOR FAX NUMBER:	
MODIFICATION PROPOSAL ORIGINATOR TELEPHONE NUMBER:	01 2370549	DATE:	11 th May 2016
MODIFICATION PROPOSAL ORIGINATOR E-MAIL ADDRESS:	LISA.MCMULLAN@EIRGRID.COM	MODIFICATION PROPOSAL NUMBER (EIRGRID USE ONLY)	MPID 269
GRID CODE SECTION(S) AFFECTED BY PROPOSAL:	PC, PCA, OC, SDC1 & SDC2, WFPS Code, Acronyms, Definitions		
GRID CODE VERSION :	6		

MODIFICATION PROPOSAL DESCRIPTION

(MUST CLEARLY STATE THE DESIRED AMENDMENT, ALL TEXT/FORMULA CHANGES TO THE GRID CODE. THE REQUIRED REASON FOR THE MODIFICATION MUST STATED. ATTACH ANY FURTHER INFORMATION IF NECESSARY.)

This modification is proposed to capture the technical requirements for new technologies that are looking to connect to the Transmission System. The ENTSOE Network Code – Requirement for Generators (NC-RfG) requires that all generators behind power electronics are classified as Power Park Modules with the same technical requirements. There are no technology specific requirements within the NC-RfG.

We are not proposing to incorporate all of the requirements of the NC-RfG into the Grid Code at this time. However in bringing forward modifications to the Grid Code in respect of new technologies looking to connect to the Transmission System, it makes sense to reference the NC RfG requirements. Therefore the NC-RfG definition of Power Park Modules is used in this Grid Code modification.

References to wind farm will be replaced with revised terminology:

Current Terms	Revised Terms
Wind Turbine Generator (WTG)	Generation Unit
Controllable WFPS <i>(with the exception of signal list #2&#3)</i>	Controllable PPM
Dispatchable WFPS	Controllable Dispatchable PPM

In addition, references to wind forecasts and wind following modes shall be replaced with new terminology.

Current Terms	Revised Terms
Wind Following Ramp Rate	Resource Following Ramp Rate
Wind Following Mode	Resource Following Mode
Wind Forecast	Resource Forecast

As an Energy Storage device is both a demand and generator user, there are additional definitions required for this PPM technology type. This type of storage is similar to Pumped Storage Plants in that there are two modes of operation, so the terminology for Energy Storage devices has been kept consistent with that for Pumped Storage Plants. There are also additional requirements for market signals for energy storage.

	<table border="1"> <tr> <th data-bbox="625 253 1169 315">New Terms</th> </tr> <tr> <td data-bbox="625 315 1169 383">Charge Capacity</td> </tr> <tr> <td data-bbox="625 383 1169 450">Energy Storage Unit (ESU)</td> </tr> <tr> <td data-bbox="625 450 1169 517">Energy Storage Power Generator</td> </tr> <tr> <td data-bbox="625 517 1169 584">Energy Storage Power Station (ESPS)</td> </tr> <tr> <td data-bbox="625 584 1169 651">Energy Storage Power Station Demand</td> </tr> <tr> <td data-bbox="625 651 1169 719">Energy Storage Power Station Generation</td> </tr> <tr> <td data-bbox="625 719 1169 786">Maximum charge capacity</td> </tr> <tr> <td data-bbox="625 786 1169 853">Minimum charge capacity</td> </tr> <tr> <td data-bbox="625 853 1169 920">Target Charge Level</td> </tr> <tr> <td data-bbox="625 920 1169 987">Target Charge Level Percentage</td> </tr> </table>	New Terms	Charge Capacity	Energy Storage Unit (ESU)	Energy Storage Power Generator	Energy Storage Power Station (ESPS)	Energy Storage Power Station Demand	Energy Storage Power Station Generation	Maximum charge capacity	Minimum charge capacity	Target Charge Level	Target Charge Level Percentage
New Terms												
Charge Capacity												
Energy Storage Unit (ESU)												
Energy Storage Power Generator												
Energy Storage Power Station (ESPS)												
Energy Storage Power Station Demand												
Energy Storage Power Station Generation												
Maximum charge capacity												
Minimum charge capacity												
Target Charge Level												
Target Charge Level Percentage												
IMPLICATION OF NOT IMPLEMENTING THE MODIFICATION	There are no specific Grid Code requirements for new technologies that are looking to connect to the transmission system, for example PV and battery storage and tidal. The Grid Code needs to be fit for purpose for the users of the Transmission System.											
<i>Please submit the Modification Proposal by fax, post or electronically, using the information supplied above</i>												
EIRGRID REVIEWER												
EIRGRID ASSESSMENT												

ACRONYMS

~~DWFPS~~ — ~~Dispatchable Wind Farm Power Station~~

ESPS Energy Storage Power Station

ESU Energy Storage Unit

PPM Power Park Module

DEFINITIONS

Active Power Control	The automatic change in Active Power output from a Controllable WFPS Controllable PPM in a response to an Active Power
-----------------------------	--

	Control Set-point received from the TSO.
Active Power Control Mode	A mode of operation of a Controllable-WFPS Controllable PPM where the Controllable-WFPS Controllable PPM has been instructed by the TSO to maintain its Active Power output at the Active Power Control Set-Point .
Active Power Control Set-point	The maximum amount of Active Power in MW, set by the TSO, that the Controllable-WFPS Controllable PPM is permitted to export.
Active Power Control Set-Point Ramp Rate	The rate of increase or decrease of Active Power output of a Controllable-WFPS Controllable PPM in response to an Active Power Control Set-point instruction.
Available Active Power	The amount of Active Power that the Controllable-WFPS Controllable PPM could produce based on current wind resource conditions. The Available Active Power shall only differ from the actual Active Power if the Controllable-WFPS Controllable PPM has been curtailed, constrained or is operating in a restrictive Frequency Response mode.
Black Start Shutdown	In the event of a Partial Shutdown or Total Shutdown of the Transmission System , the Controllable-WFPS Controllable PPM shall be sent a Black Start Shutdown signal by the TSO and upon receipt of the signal, the Controllable-WFPS Controllable PPM shall trip the circuit breaker(s) at the Connection Point and shutdown the Controllable-WFPS Controllable PPM in a controlled manner.
Central Dispatch	<p>The process of Scheduling and issuing Dispatch Instructions directly to a Control Facility by the TSO pursuant to the Grid Code.</p> <p>All Dispatchable WFPSSs PPMs, Interconnectors, Pumped Storage Plant Demand, Energy Storage Power Station Demand, Demand Side Units, and Aggregated Generating Units are subject to Central Dispatch. In relation to all other Generation Units, thresholds apply as follows:</p> <ul style="list-style-type: none"> ▪ all other Generation Units with a Registered Capacity of 10 MW or more are subject to Central Dispatch; ▪ all other Generation Units with a Registered Capacity of 5 MW or more and less than 10 MW are not subject to Central Dispatch unless required by the TSO; however,

	<p>such Generation Units can elect to be subject to Central Dispatch;</p> <ul style="list-style-type: none"> ▪ all other Generation Units with a Registered Capacity of less than 5 MW are not subject to Central Dispatch unless required by the TSO; ▪ any Power Station, which has an aggregate Registered Capacity of 10 MW or more, consisting of more than one Generation Unit that is not otherwise subject to Central Dispatch, is subject to Central Dispatch as an Aggregated Generating Unit; ▪ all Generation Units with a Registered Capacity of less than 10 MW can elect whether to comply with SDC1.4.4.5 relating to the submission of Commercial Offer Data.
Centrally Dispatched Generating Unit	A Generating Unit within a Power Station subject to Central Dispatch , which comprises, unless specified otherwise in relation to a particular use of the term, a Thermal Plant including a CCGT Installation , a Dispatchable WFPSs PPMs , Hydro Unit and Pumped Storage Plant in respect of its Pumped Storage Generation .
Charging Capacity	The maximum amount of Energy consumed by Energy Storage Power Station when acting as a Energy Storage Power Station Demand .
Collector Network	The network of cables and overhead lines within a Controllable WFPS Controllable PPM used to convey electricity from individual WTGs Generation Units to the Connection Point .
Commissioning Test	Testing of a CDGU , Controllable WFPS Controllable PPM , Pumped Storage Plant Demand , Demand Side Units , Aggregated Generating Units , Interconnector or an item of User's Equipment required pursuant to the Connection Conditions prior to connection or re-connection in order to determine whether or not it is suitable for connection to the System and also to determine the new values of parameters to apply to it following a material alteration or modification of a CDGU , Controllable WFPS Controllable PPM , Pumped Storage Plant Demand , Demand Side Units , Aggregated Generating Units , Interconnector or of an item of User's Equipment and the term "Commissioning Testing" shall be construed accordingly.
Connection Point	The physical point where the User's Plant Apparatus or System

	is joined to the Transmission System or the Distribution System .
Controllable PPM	A site containing at least one PPM can automatically act upon a remote signal from the TSO to change its Active Power output.
Controllable WFPS Controllable PPM Availability	The amount of MW the Controllable WFPS Controllable PPM can produce given favourable wind resource conditions.
Controllable WFPS Controllable PPM MW Availability Declaration	A measure of the maximum Active Power output which can be produced by a Controllable WFPS Controllable PPM S given favourable wind resource conditions. Account shall be taken of partial and/or full outages of individual WTG Generation Unit within the Controllable WFPS Controllable PPM .
Controllable WFPS Controllable PPM Operator	The operator of the Controllable WFPS Controllable PPM .
Controlled Active Power	The amount of Active Power that a Controllable WFPS Controllable PPM is permitted to export based on the Active Power Control Set-point signal sent by the TSO .
Design Minimum Operating Level (DMOL):	The minimum Active Power output of Controllable WFPS Controllable PPM where all WTGs Generation Units are generating electricity and capable of ramping upwards at any of the specified ramp rates (given available wind resource), and shall not be greater than 12% of Registered Capacity .
Dispatchable WFPS PPM	A Controllable WFPS Controllable PPM which must have a Control Facility in order to be dispatched via an Electronic Interface by the TSO .
Energy Storage Generator	A Generator which owns and/or operates any Energy Storage Power Station .
Energy Storage Power Station (ESPS)	A site containing at least one ESU can automatically act upon a remote signal from the TSO to change its Active Power output.
Energy Storage Power Station (ESPS) Demand	An Energy Storage Power Station in its operation of consuming Energy .
Energy Storage Power Station (ESPS) Generation	An Energy Storage Power Station in its operation of producing Energy.
Energy Storage Unit (ESU)	A Generation Unit(s) using storage devices to generate and consume electricity as a or as part of, a PPM .
Frequency Response Ramp	The minimum rate of increase or decrease of Active Power output

Rate	of a Controllable WFPS Controllable PPM when acting to control Transmission System Frequency .
Governor Droop	The percentage drop in the Frequency that would cause the Generation Unit under free governor action to change its output from zero to its full Capacity . In the case of a Controllable WFPS Controllable PPM , it is the percentage drop in the Frequency that would cause the Controllable WFPS Controllable PPM to increase its output from zero to its full Registered Capacity .
Maximum Charge Capacity	The maximum amount of Energy that can be produced from the storage of an Energy Storage Generator for a Trading Day .
Merit Order	An order, compiled by the TSO in conjunction with the Other TSO pursuant to SDC1, of CDGUs , Controllable WFPSs Controllable PPMs , Demand Side Units , Pumped Storage Plant Demand and Aggregated Generating Units Price Sets and/or Interconnector Price Quantity Pairs or Price Quantity Pairs of equivalent units in Northern Ireland.
Minimum Charge Capacity	The minimum amount of Energy that must be produced from the storage of an Energy Storage Generator for a Trading Day .
Power Park Module (PPM)	A Generation Unit or ensemble of Generation Units generating electricity which; <ul style="list-style-type: none"> • Is connected to the Network non-synchronously or through power electronics, • Has a single Connection Point to a Transmission System, Distribution System or HVDC System
Registered Capacity	The maximum Capacity , expressed in whole MW, that a Generation Unit can deliver on a sustained basis, without accelerated loss of equipment life, at the Connection Point which is under the dispatch (or control of a Controllable WFPS Controllable PPM) of the TSO . This shall be the value at 10°C, 70 % relative humidity and 1013 hPa. The values of an Interconnector's Operating Characteristics for operation of the Interconnector pursuant to the Grid Code registered under the Connection Conditions .
Rise Time	In relation to reactive current response from Controllable WFPS Controllable PPM , it is the length of time from Fault Inception for reactive current to reach 90% of its steady-state value.
Rota Load Shedding Plan	A plan that provides for disconnection and reconnection of defined

	blocks of demand on instruction from the TSO
Safety Rules	ESB Networks Electrical Safety Rules, ESB Power Generation Electrical Safety Rules or the rules of a User , compliance with which ensures that persons working on Plant and/or Apparatus to which the rules apply are safeguarded from hazards arising from the System .
Settling Time	In relation to reactive current response from Controllable-WFPS Controllable PPM , it is the length of time from Fault Inception for reactive current to settle within +/-10% of its steady-state value.
Target Charge Level Percentage	As defined in the TSC .
Target Charge Levels	Part of the Commercial Offer Data for an Energy Storage Power Station Generator and means the target level of the storage for the end of the Trading Day .
TSO Telecommunication Interface Cabinet	The physical interface point between the TSO's telecommunications equipment and the Controllable-WFPS's Controllable PPM's control equipment.
Voltage Regulation System Slope Setting	The percentage change in Transmission System Voltage that would cause the Reactive Power output of the Interconnector to vary from maximum Mvar production to maximum Mvar absorption or vice-versa or Controllable-WFPS Controllable PPM to vary from maximum Mvar production capability of Q/Pmax of 0.33 to maximum Mvar absorption capability of Q/Pmax of -0.33 or vice-versa, as per Figure WFPS PPM 1.4.
WFPS PPM Extension	An increase to the Registered Capacity of any Controllable-WFPS Controllable PPM .
Wind-Farm PPM Control System	The control system at the Controllable-WFPS Controllable PPM which provides for Active Power Control , Frequency Response , ramp rate control and other WTG Generation Unit control features.
Wind Resource Following Mode	A mode of operation of a Controllable-WFPS Controllable PPM where the system frequency is within normal range and the Controllable-WFPS Controllable PPM is not under Active Power Control by the TSO , allowing the Controllable-WFPS Controllable PPM to produce up to 100% of its Available Active Power , depending on the Power-Frequency Curve in operation. When operating on Power-Frequency Curve 2, the Controllable-WFPS

	<p>Controllable PPM is required to maintain its Active Power output at a fixed percentage of its Available Active Power when Transmission System Frequency is within the range F_B-F_C.</p>
<p>Wind Resource Following Ramp Rate</p>	<p>The maximum rate of increase of Active Power output of a Controllable-WFPS Controllable PPM in response to an increase in wind-speed resource availability.</p>

PC.4.5 Notice Required

Any **User** proposing to de-rate, close, retire, withdraw from service or otherwise cease to maintain and keep available for **Dispatch** in accordance with **Good Industry Practice** any **Generation Unit** or **Generation Units** or ~~Controllable WFPSs~~ **Controllable PPMs** with **Registered Capacity** greater than 50 MW in aggregate shall give the **TSO** at least 36 calendar months' notice of such action and any **Generation Unit** or **Generation Units** or ~~Controllable WFPSs~~ **Controllable PPMs** with **Registered Capacity** less than or equal to 50 MW in aggregate shall give the **TSO** at least 24 calendar months' notice of such action.

PC.A4.10 ~~Wind Turbine Generators~~ Power Park Modules and Mains Excited Asynchronous Generators

State whether turbines are Fixed Speed or Variable Speed:

- Please provide manufacturer details on electrical characteristics and operating performance with particular reference to Flicker and Harmonic performance.
- Please provide details of the anticipated operating regime of generation, i.e. continuous, seasonal etc. List the anticipated maximum export level in MW for each calendar month, and indicate how generation would vary over a typical 24 hour period during the month of maximum export.
- Give details of expected rapid or frequent variations in output, including magnitude, max rate of change expected, frequency and duration.

PC.A4.10.1 MODELLING REQUIREMENTS FOR ~~WIND TURBINE GENERATORS~~ PPMs

PC.A4.10.1.1 INTRODUCTION

The **TSO** requires suitable and accurate dynamic models for all **Generators** connected to, or applying for a connection to, the transmission system in order to assess reliably the impact of the **Generator's** proposed installation on the dynamic performance and security and stability of the **Power System**.

Modelling requirements for thermal and hydro **Generators** are processed on the identification by the applicant of the relevant PSS/E library model and the provision of the applicable data parameters in the current, appropriate application form. Where there are no suitable library models available, specially written models are supplied. These are known in PSS/E as "user-written models".

Currently (September 2004) there are no suitable PSS/E library models for ~~Wind Turbine Generators PPMs~~. As a result, the TSO requires ~~Controllable WFPSs~~ **Controllable PPMs** greater than 5MW to provide specially written models and associated data parameters specific to the ~~Wind Turbine Generators PPMs~~ and any associated controls and reactive compensation equipment to be used in the applicant's ~~Controllable WFPSs~~ **Controllable PPMs** scheme. The requirements of these models are as outlined in this section of the **Planning Code** Appendix.

PC.A4.10.1.2 ~~WIND TURBINE GENERATOR PPM~~ DYNAMIC MODELS

PC.A4.10.1.2.1 Requirement to provide a dynamic model

Each ~~Controllable WFPS~~ **Controllable PPM** shall provide a dynamic model, or shall provide an unambiguous reference to a dynamic model previously provided to the TSO, appropriate for the ~~Controllable WFPS~~ **Controllable PPM**. If all the ~~Wind Turbine Generators PPMs~~ in the ~~Controllable WFPS~~ **Controllable PPM** are not identical, the model shall incorporate separate modules to represent each type of ~~Wind Turbine Generators PPMs~~. Appropriate data and parameter values must be provided for each model. The model shall be provided in PSS/E format, or in such other format as may be agreed between the ~~Controllable WFPS~~ **Controllable PPM** and the TSO.

The models for ~~Wind Turbine Generators PPMs~~ and the ~~Controllable WFPS~~ **Controllable PPM** (computer software based on a mathematical representation of the behaviour of the machine) must be able to calculate how quantities such as **Active Power** output, **Reactive Power** output, turbine speed etc. vary as factors such as the **Voltage** at the **Connection Point** change. They must take account of the inherent characteristics of the machines and the actions of the ~~WTG~~ **Generation Unit** control systems and any relevant ~~Controllable WFPS~~ **Controllable PPM** control systems.

The models provided shall be treated as **Preliminary Project Planning Data**, **Committed Project Planning Data** or **System Planning Data** as appropriate, as set out in PC.6 of the **Planning Code**.

PC.A4.10.1.2.2 Computer environment

These models must run on the PSS/E software for the Irish network. They must not require a simulation time step of less than 5ms. Details of the current PSS/E version, computer platform, compiler version etc, will be provided by the TSO upon request. The TSO may from time to time request that the models be updated to be compatible with changes in the TSO's computing environment. Each ~~Controllable WFPS~~ **Controllable PPM** shall ensure that such updated models are provided without undue delay.

PC.A4.10.1.2.3 Features to be represented in the dynamic model

The dynamic model must represent the features and phenomena likely to be relevant to angular and **Voltage** stability. These features include but may not be limited to:

- a) the electrical characteristics of the **Generator**;
- b) the separate mechanical characteristics of the turbine and the **Generator** and the drive train between them;
- c) variation of power co-efficient with pitch angle and tip speed ratio;
- d) blade pitch control;
- e) converter controls;
- f) reactive compensation;
- g) protection relays.

PC.A4.10.1.2.4 Model aggregation

For computational reasons, it is essential that the models of individual **WTGs Generation Units** can be aggregated into a smaller number of models, each representing a number of **WTGs Generation Units** at the same site. A representation of the collector network may be included in the aggregate model of the **Controllable-WFPS Controllable PPM**.

PC.A4.10.1.2.5 Model documentation

The model should be fully documented. The documentation should describe in detail the model structure, inputs, outputs and how to set up and use the model and should be based on the documentation of standard PSS/E library models.

The **TSO** may, when necessary to ensure the proper running of its complete system representation or to facilitate its understanding of the results of a dynamic simulation, request additional information concerning the model, including the source code of one or more routines in the model. The **Controllable-WFPS Controllable PPM** shall comply with any such request without delay. Where the **Controllable-WFPS Controllable PPM** or any other party (acting reasonably) designates such information as confidential on the basis that it incorporates trade secrets, the **TSO** shall not disclose the information so designated to any third party.

PC.A4.10.1.2.6 Time to Comply

Where a **User** requires reasonable time to develop the necessary model or models so as to comply fully with all the provisions in this section **PCA 4.10.1.2**, the **User** may apply to the **TSO** to be deemed compliant with the provisions of **PCA 4.10.1.2** on the basis of **GC.10.1.3** of the **General Conditions** of the **Grid Code**. The **TSO** shall consider any such application in accordance with **GC.10.1.3**, and if the **TSO** is satisfied as to the **User's** programme for developing and testing the necessary dynamic model, the **TSO** may, for so long as the **TSO** is so satisfied, treat the **User** as being in compliance with the provisions of this section. If the **TSO** decides, acting reasonably, that it is not satisfied as to the **User's** programme for developing and

testing the necessary dynamic model and that the **User** cannot be deemed to be in compliance with **PCA 4.10.1.2**, the provisions of **GC.10.1.4** shall apply and the **User** shall apply for a derogation under the terms of GC.9.

PC.A4.10.1.3 VALIDATION OF MODEL

All models provided to the **TSO** for use in dynamic simulations must be validated. The **TSO** must be satisfied that the behaviour shown by the model under simulated conditions is representative of the behaviour of the real equipment under equivalent conditions.

For validation purposes the ~~Controllable-WFPS~~ **Controllable PPM** shall ensure that appropriate tests are performed and measurements taken to assess the validity of the dynamic model. Where the validity of the model has not been confirmed prior to the commissioning of the ~~Controllable-WFPS~~ **Controllable PPM**, appropriate tests shall be carried out and measurements taken at the ~~Controllable-WFPS~~ **Controllable PPM** to assess the validity of the dynamic model. The tests and measurements required shall be agreed with the **TSO**.

The ~~Controllable-WFPS~~ **Controllable PPM** shall provide the **TSO** with all available information showing how the predicted behaviour of the dynamic model to be verified compares with the actual observed behaviour of a prototype or production ~~WTG~~ **Generation Unit** under laboratory conditions and/or actual observed behaviour of the real ~~WTG~~ **Generation Unit** as installed and connected to a transmission or distribution network.

If the on-site measurements or other information provided indicate that the dynamic model is not valid in one or more respects, the ~~Controllable-WFPS~~ **Controllable PPM** shall provide a revised model whose behaviour corresponds to the observed on-site behaviour as soon as reasonably practicable.

The conditions validated should as far as possible be similar to those of interest, e.g. low short circuit level at **Connection Point**, close up, severe faults, nearby moderate faults, remote faults, **Voltage** excursions, **Frequency** excursions, large ~~wind-speed~~ **resource availability** variations.

PC.A4.10.1.4 ~~WIND-FARM POWER PARK MODULE DATA~~

In order to construct a valid dynamic model of each ~~Controllable-WFPS~~ **Controllable PPM**, the following ~~Controllable-WFPS~~ **Controllable PPM** data is required:

~~Wind Turbine Generator (WTG)~~ **Generation Unit transformer**

This is the transformer that connects the ~~WTG~~ **Generation Unit** with the internal ~~Controllable-WFPS~~ **Controllable PPM** network.

Rating of **WTG Generation Unit** transformer (MVA or kVA)

WTG Generation Unit transformer voltage ratio (kV)

WTG Generation Unit transformer impedance (%)

Internal **Controllable WFPS Controllable PPM** network and corresponding data

Please describe how the **Controllable WFPS's Controllable PPM's** internal network structure (collector network) will be laid out (by means of a single-line diagram or other description of connections). The description should include a breakdown of how the individual **WTGs Generation Units** are connected together as well as how they are connected back to the **Controllable WFPS Controllable PPM** substation. Please specify different cable or overhead line types and the individual length of each section of circuit.

	Type1	Type2	Type3	Extend
Total length (m)				Table
Conductor cross section area per core (mm)				as appropriate
Conductor type (Al, Cu, etc)				
Type of insulation				
Charging capacitance ($\mu\text{F}/\text{km}$)				
Charging current (Ampere/km)				
Positive sequence resistance ($R1 \text{ Ohm}/\text{km}$)				
Positive sequence reactance ($X1 \text{ Ohm}/\text{km}$)				

Grid connected transformer

This is the transformer that is connecting the **Controllable WFPS Controllable PPM** site with the **Distribution/Transmission System (equivalent to the Generator Transformer of a conventional power station)**. Data is required for this transformer as follows:

Rating of grid transformer (MVA or kVA)

Transformer **Voltage** ratio (kV)

Transformer impedance (%)

Reactive compensation installed at site

Number of inductive devices

Indicate for each device the inductive **Mvar** capability. If the device has more than one stage please indicate the number of stages and the **Mvar** capability switched in each stage i.e. 0.5 **Mvar** in 5 steps etc.

Number of capacitive devices

Indicate for each device the Capacitive **Mvar** capability. If the device has more than one stage please indicate the number of stages and the **Mvar** capability switched in each stage i.e. 0.5 **Mvar** in 5 steps etc.

Method of voltage/reactive power control applied to each controllable reactive compensation device. This information should be provided in sufficient detail (e.g. transfer function block diagram, control system gain/droop, deadband and hysteresis characteristics, tap steps, etc.) to allow an appropriate PSS/E model to be developed.

OC7.1.3.1 OC7.1 applies to the **TSO** and to **Users**, which term in OC7.1 means:-

- (a) **Generators;**
- (b) **Interconnector Operators;**
- (c) ~~Dispatchable WFPSs~~ **Dispatchable PPMs;**
- (d) **Distribution System Operator;**
- (e) **Demand Customers;** and
- (f) **Demand Side Unit Operators.**

OC7.2.3.1 OC7.2 applies to the **TSO** and to **Users**, which term in OC7.2 means:

- (a) **Generators;**
- (b) **Interconnector Operators;**
- (c) ~~Dispatchable WFPS~~ **Dispatchable PPM;**
- (d) **Distribution System Operator;**
- (e) **Demand Customers;** and
- (f) **Demand Side Unit Operator.**

OC7.2.4.5 ~~Dispatchable WFPSs~~ **Dispatchable PPMs**

OC7.2.4.5.1 The ~~Dispatchable WFPS's~~ **Dispatchable PPM's** contact locations and personnel referred to in this Section OC7.2.4.5 shall be notified by the ~~Dispatchable WFPS~~ **Dispatchable PPM** to the **TSO** prior to connection and thereafter updated as appropriate.

OC7.2.4.5.2 The ~~Dispatchable WFPS~~ **Dispatchable PPM** is required to provide a **Control Facility**. The ~~Dispatchable WFPS~~ **Dispatchable PPM** shall ensure acting in accordance with **Good Industry Practice** that the **Control Facility** is staffed at appropriate staffing levels at all times.

OC7.2.4.5.3 The **Control Facility** shall be staffed by a **Responsible Operator(s)** who shall respond to communications from the **TSO** without undue delay (except where otherwise provided for by agreement between the ~~Dispatchable WFPS~~ **Dispatchable PPM** and the **TSO**, such agreement not to be unreasonably withheld) and are of suitable experience and training and are authorised to perform the following functions on behalf of the ~~Dispatchable WFPS~~ **Dispatchable PPM**:

- (a) to accept and execute **Dispatch Instructions** as per **SDC2**; and

- (b) to receive and acknowledge receipt of requests, for amongst other matters, operation outside the **Declared** values of **Availability**, **Ancillary Service** capability, or operation of the ~~Dispatchable-WFPS~~ **Dispatchable PPM** during **System Emergency Conditions**.

OC7.2.4.5.4 At any point in time, a single person shall be designated by the ~~Dispatchable-WFPS~~ **Dispatchable PPM** and notified to the **TSO** as the **Responsible Manager**. The **Responsible Manager** shall be responsible for dealing with the **TSO** on matters relating to the **Grid Code** other than as provided for in OC7.2.4.2.2 and OC7.2.4.2.3. In the event that the **Responsible Manager** is not a person on duty at the **Control Facility**, then the **Responsible Manager** must be capable of being contacted from the **Control Facility** at all times, and in the event that the **TSO** issues a request to the **Control Facility** requiring the **Responsible Manager** to contact the **NCC**, the **Responsible Manager** shall comply with the request without undue delay and in any case within 15 minutes of the request.

OC7.2.4.5.5 The **Responsible Manager** shall be authorised by the ~~Dispatchable-WFPS~~ **Dispatchable PPM** to perform the following functions on behalf of the **Dispatchable WFPS**:

- (a) to submit and revise an **Availability Notice** and other data under SDC1 for the ~~Dispatchable-WFPS~~ **Dispatchable PPM**;
- (c) to communicate with respect to issues regarding **Outages** of the ~~Dispatchable WFPS~~ **Dispatchable PPM**.

The ~~Dispatchable-WFPS~~ **Dispatchable PPM** may, from time to time, notify a replacement contact location and personnel which meets the foregoing requirements.

SDC1 SCHEDULING AND DISPATCH CODE NO.1

UNIT SCHEDULING

SDC1.1 INTRODUCTION

SDC1.1.1 SEM Provisions

- (a) This Scheduling and Dispatch Code No. 1 ("SDC1") forms part of the **Sections under Common Governance** of the **Grid Code**. The **Sections under Common Governance** are those parts of the **Grid Code** which are under common governance in both the **Grid Code** and the **Other Grid Code**.
- (b) The form of this SDC1 is similar to the SDC1 in the **Other Grid Code**. Differences relate to references to relevant power systems and related terms. Where there is a difference between a provision in this **Grid Code** and an equivalent provision in the **Other Grid Code**, the wording in question is shaded in grey. In addition, those parts of this SDC1 that are not part of the **Other Grid Code** are shaded in grey in this SDC1. Differences between the form of this SDC1 and the SDC1 in the **Other Grid Code** are summarised in Annex 1 to this SDC1.
- (c) This SDC1 is intended to work in conjunction with other documents, including the **Trading and Settlement Code ("TSC")**. The provisions of the **Grid Code** and the **Other Grid Code** will take precedence over the **TSC**. The **TSC** is the document under which the principal elements of the market for electricity operate. Every **User** which trades in electricity above certain minimum thresholds or their **Intermediary** shall be a party to the **TSC**. The **Market Operator** is a party to the **TSC**, as is the **TSO** and the **Other TSO**.
- (d) The obligation to submit data in relation to some of the information required to be provided to the **TSO** by this SDC1 may be fulfilled by **Users** where such information submitted under the **TSC** by a **User** or by an **Intermediary** on behalf of **Users** is then provided to the **TSO** by the **Market Operator** under the provisions of the **TSC**, as further provided in this SDC1. The **TSO** may require **Users** to verify or provide revisions to data received by it via the **Market Operator**.
- (e) Further provisions dealing with the **Sections under Common Governance** are contained in the **General Conditions**.

SDC1.1.2 SDC1 sets out the procedure for:

- (a) **Availability**: the daily submission by a **User** to the **TSO** of an **Availability Notice** in respect of any of its:
 - (i) **CDGUs** (which for the avoidance of doubt comprise, **Generating Units** subject to **Central Dispatch**, **CCGT Installations**, **Hydro Units**, **Pumped Storage Generation** (but not **Pumped Storage Plant Demand** or **Energy Storage Power Station Demand**) and **Dispatchable WFPs**);
 - (ii) **Pumped Storage Plant Demand**;
 - (iii) **Energy Storage Power Station Demand**;

~~(iii)~~ (iv) **Interconnector Availability** (in the case of the **Interconnector Owner**) and **Price** (in the case of an **Interconnector User**);

~~(iv)~~ (v) **Demand Side Units**;

~~(v)~~ (vi) in the case of **Generator Aggregators**, its **Aggregated Generating Units**; and

~~(vi)~~ (vii) ~~**Controllable WFPSs**~~ **Controllable PPMs**.

(b) **Technical Parameters**: the daily notification to the **TSO** of the **Technical Parameters**, in respect of the following **Trading Day**, by each **User** in a **Technical Parameters Notice**, notification of **Other Relevant Data** and notification of other technical data including **Ancillary Services** capability;

(c) **Commercial Offer Data**: the daily notification of **Commercial Offer Data**;

(d) **Revisions/Re-declarations**: revisions / **Re-declarations** of such information (other than **Commercial Offer Data** after **Gate Closure**) as provided for this in SDC1;

(e) **Indicative Operations Schedule**: the production and issuing by the **TSO** of an **Indicative Operations Schedule** the day before the **Trading Day** as a statement of which:

(i) **CDGUs**;

(ii) **Pumped Storage Plant Demand**;

(iii) **Energy Storage Power Station Demand**;

~~(iii)~~ (iv) **Interconnectors**;

~~(iv)~~ (v) **Demand Side Units**;

~~(v)~~ (vi) **Aggregated Generating Units**; and/or

(vii) ~~**Controllable WFPSs**~~ **Controllable PPMs**

may be required.

SDC1.1.3 In this SDC1, the term "**Gate Closure**" shall mean 10.00 hours on the day preceding the relevant **Trading Day** to which the notice relates (D-1).

SDC1.1.4 **INTRA-DAY TRADING**

There are three **Gate Windows**, denoted EA1 (Ex-Ante 1), EA2 (Ex-Ante 2), and WD1 (Within-day 1), and three associated **Trading Windows**. The rules for **Users** to submit new or revised data related to the three associated **Trading Windows** are set out in the **TSC**.

The timings of the key events for **Intra-Day Trading** are set out in the table below.

Gate Window	EA1	EA2	WD1
Gate Window Opening	06:00 on D-29	09:30 on D-1	11:30 on D-1
Gate Window Closure	09:30 on D-1	11:30 on D-1	08:00 on D
Trading Windows			
Start of Trading Window	Start of Trading Day (Trading	Start of Trading Day (Trading	Trading Period starting 18:00

	Period starting 06:00)	Period starting 06:00)	
End of Trading Window	End of Trading Day (Trading Period Starting 05:30)	End of Trading Day (Trading Period Starting 05:30)	End of Trading Day (Trading Period Starting 05:30)

SDC1.2

OBJECTIVE

The objectives of SDC1 are:

- (a) to enable the **TSO**, in conjunction with the **Other TSO**, to prepare an **Indicative Operations Schedule** (utilising, amongst other things, a **Merit Order**) by 16.00 hours on the day preceding the relevant **Trading Day (D-1)** to be used in the **Scheduling** and **Dispatch** process for that **Trading Day**;
- (b) to thereby ensure (so far as possible) the integrity of the **Transmission System** and to ensure that the **TSO** acts in conjunction with the **Other TSO** so that the **Other TSO** can ensure the integrity of the **Other Transmission System** (with the **Other TSO** having a similar objective);
- (c) to ensure the security and quality of supply in relation to the **Transmission System** and to ensure that the **TSO** acts in conjunction with the **Other TSO** so that the **Other TSO** can ensure the security and quality of supply in relation to the **Other Transmission System** (with the **Other TSO** having a similar objective);
- (d) to ensure that there is sufficient capacity to meet the electrical power demand, and thereby in conjunction with the **Other TSO** to ensure that there is sufficient capacity to meet the demand on the Island of Ireland at all times and in both cases together with an appropriate margin of reserve;
- (e) to publish an **Indicative Operations Schedule** as provided for in this SDC1.

SDC1.3

SCOPE

SDC1 applies to the **TSO** and to the following **Users**:

- (a) **Generators** with regard to their:
CDGUs; and
~~Controllable WFPSs~~ **Controllable PPMs**.
- (b) **Pumped Storage Generators** with regard to their **Pumped Storage Plant Demand**;
- (c) **Energy Storage Generators** with regard to their **Energy Storage Power Station Demand**;
- ~~(d)~~ (d) **Interconnector Owners** with regard to their **Interconnectors**;
- ~~(d)~~ (e) In respect of the submission of **Commercial Offer Data** under SDC1.4.4.5 only, **Interconnector Users** in respect of their **Interconnector Units**;

- ~~(e)~~ (f) **Demand Side Unit Operators** in relation to their **Demand Side Units**; and
- ~~(f)~~ (g) **Generator Aggregators** in respect of their **Aggregated Generating Units**.

Each of which (other than the **TSO**) is a “**User**” under this SDC1.

SDC1.4

PROCEDURE

SDC1.4.1

Availability Notice

SDC1.4.1.1

Requirement

- (a) Each **User** shall, by not later than the EA1 **Gate Window Closures** each day, notify the **TSO** by means of an **Availability Notice** (in such form as the **TSO** may reasonably notify from time to time or in the form published on the **TSO** website) of changes to the **Availability**, available transfer capacity and/or **Demand Side Unit MW Availability** (as the case may be) of each of its:
 - (i) **CDGUs**;
 - (ii) ~~Controllable WFPSs~~ **Controllable PPMs**;
 - (iii) **Pumped Storage Plant Demand**;
 - (iv) Energy Storage Plant Demand**;
 - ~~(iv)~~ (v) **Interconnectors** (to be submitted by the **Interconnector Owner**);
 - ~~(v)~~ (vi) **Demand Side Units**; or
 - (vii) **Aggregated Generating Units** as the case may be.
- (b) A **User** may satisfy this obligation by submitting the data under the **TSC**, unless the **TSO** requires, by notice to the **User**, the data to be submitted to it directly under the **Grid Code**.
- (c) A **Generator Aggregator** will satisfy the obligation in this SDC1.4.1.1 by notifying to the **TSO** in an **Availability Notice** in the form described in paragraph (a) above the **Availability** of its **Aggregated Generating Units** as the case may be.

SDC1.4.1.2

Content

- (a) The **Availability Notice** shall state the:
 - (i) **Availability** of the relevant:
 - **CDGU**; or
 - ~~Controllable WFPSs~~ **Controllable PPMs**; or
 - (ii) the **Demand Side Unit MW Availability** of the **Demand Side Unit** or **Pumped Storage Plant Demand** or **Energy Storage Power Station Demand**; or

- (iii) the available transfer capacity as defined in the **TSC** in respect of an **Interconnector**;

as the case may be, (including, in the case of a **CCGT Installation**, the **Availability** of each of the **CCGT Units** within it) for each **Trading Period** in the following **Optimisation Time Horizon** (subject to revision under SDC1.4.5.1(a)). The **Availability Notice** submitted in relation to an **Optimisation Time Horizon** will supersede the previous one in relation to that part of the previous **Optimisation Time Horizon** which is covered by the new one.

- (b) In the case of a **Generator Aggregator**, the **Availability Notice** shall state the **Availability** of its **Aggregated Generating Units** as a whole.

SDC1.4.1.3 Whole Numbers: The **MW** figure stated in the **Availability Notice** shall be a whole number.

SDC1.4.1.4 Atmospheric Conditions: In the case of **CDGUs** and ~~Controllable WFPs~~ **Controllable PPMs** which are affected by ambient conditions, an **Availability Notice** submitted by a **Generator** shall be stated as being the **User's** best estimate of the prevailing atmospheric conditions for the **Trading Period** to which each part of the **Availability Notice** relates.

SDC1.4.2 Additional Grid Code Availability Notice

The following items are required to be submitted by each **User** by no later than the **EA1 Gate Window Closure** each day, with the exception of **Aggregators** and **Demand Side Unit Operator**, direct to the **TSO**, regardless of whether these have to be submitted under the **TSC**. The requirements in SDC1.4.1 in relation to data apply to this SDC1.4.2 as if repeated here.

SDC1.4.2.1 Fuels: In the case where a **CDGU** is capable of firing on different fuels, then the **Generator** shall submit an **Availability Notice** setting out the information in SDC1.4.1 above for each fuel for the **CDGU**.

SDC1.4.2.2 CCGT Availability

- (a) The **Availability** of each **CCGT Unit** within each **CCGT Installation**;
- (b) In the case of a **CCGT Installation**, the **CCGT Installation Matrix** submitted by the **Generator** under *PC.A4.3 of the Planning Code Appendix* (as may be revised as therein provided is used and relied upon by the **TSO** as a 'look up table' to determine the number of **CCGT Units** within a **CCGT Installation** which will be synchronised to achieve the **MW Output** specified in a **Dispatch Instruction**. When using a **CCGT Installation Matrix** for **Scheduling** purposes, the **TSO** will take account of any updated information on the individual **Availability** of each **CCGT Unit** contained in an **Availability Notice** submitted by a **Generator** pursuant to this SDC1. The individual **Availability** figures submitted under this SDC1.4.2.2 must be consistent with the **Generator's** submission under the **TSC**.
- (c) It is accepted that in cases of change in **MW Output** in response to **Dispatch** instructions issued by the **TSO**, there may be a transitional variance to the conditions reflected in the **CCGT Installation Matrix**. Each **Generator** shall notify the **TSO** as soon as practicable after the event of any such variance.

- (d) In achieving a **Dispatch Instruction** the range or number of **CCGT Units** envisaged in moving from one **MW Output** level to the other should not be departed from.
- (e) There is a provision in SDC1.4.5 for the **Generator** to revise the individual **Availability** of each **CCGT Unit** within each **CCGT Installations**, subject always to the provisions of this SDC1.4.2.2;

SDC1.4.3 **General Availability Requirements**

SDC1.4.3.1 **Availability of Generating Units**

Each **Generator** and **Generator Aggregator** shall in relation to its **CDGUs**, ~~Controllable WFPSs~~ **Controllable PPMs** or **Aggregated Generating Units** maintain, repair, operate and fuel the **CDGU** and/or ~~Controllable WFPS~~ **Controllable PPM** and/or **Aggregated Generating Unit** as required by **Prudent Utility Practice** and any legal requirements applicable to its jurisdiction, with a view to providing the required **Ancillary Services** as provided for in an **Ancillary Services Agreement**.

SDC1.4.3.2 Each **Generator**, and where relevant each **Generator Aggregator**, shall, subject to the exceptions in SDC1.4.3.3, use reasonable endeavours to ensure that it does not at any time declare in the case of its **CDGU**, ~~Controllable WFPS~~ **Controllable PPM**, or **Aggregated Generating Unit**, the **Availability** or **Technical Parameters** at levels or values different from those that the **CDGU**, ~~Controllable WFPS~~ **Controllable PPM**, and/or an **Aggregated Generating Unit** could achieve at the relevant time. The **TSO** can reject declarations to the extent that they do not meet these requirements.

SDC1.4.3.3 SDC1.4.3.2 shall not apply to the extent:

- (a) it would require the **Generator** or, where relevant, the **Generator Aggregator** to declare levels or values better than the **Registered Capacity** and **Technical Parameters** as submitted under the **Planning Code** in respect of a **CDGU**, a ~~Controllable WFPS~~ **Controllable PPM** and/or an **Aggregated Generating Unit**;
- (b) necessary during periods of **Scheduled Outage** or **Short Term Scheduled Outage** or otherwise with the consent of the **TSO**;
- (c) necessary while repairing or maintaining the **CDGU**, the ~~Controllable WFPS~~ **Controllable PPM** and/or the **Aggregated Generating Unit** or equipment necessary to the operation of the **CDGU**, the ~~Controllable WFPS~~ **Controllable PPM** and/or the **Aggregated Generating Unit** where such repair or maintenance cannot reasonably, in accordance with **Prudent Utility Practice**, be deferred to a period of **Scheduled Outage** or **Short Term Scheduled Outage**;
- (d) necessary to avoid an imminent risk of injury to persons or material damage to property (including the **CDGU**, the ~~Controllable WFPS~~ **Controllable PPM** and/or the **Aggregated Generating Unit**); or
- (e) it is not lawful for the **Generator** to operate the **CDGU**, the ~~Controllable WFPS~~ **Controllable PPM** and/or the **Aggregated Generating Units**.

SDC1.4.3.4 **Availability of Demand Side Units**

Each **Demand Side Unit Operator** shall, subject to the exceptions in SDC1.4.3.5, use reasonable endeavours to ensure that it does not at any time declare the

Demand Side Unit MW Availability and the **Demand Side Unit** characteristics of its **Demand Side Unit** at levels or values different from those that the **Demand Side Unit** could achieve at the relevant time. The **TSO** can reject declarations to the extent that they do not meet these requirements.

SDC1.4.3.5 SDC1.4.3.4 shall not apply to the extent:

- (a) it would require the **Demand Side Unit Operator** to declare levels or values better than **Demand Side Unit MW Capacity** and **Technical Parameters** as submitted under the Planning Code in respect of a **Demand Side Unit**;
- (b) necessary during periods of **Scheduled Outage** or **Short Term Scheduled Outage** or otherwise with the consent of the **TSO**;
- (c) necessary while repairing or maintaining the **Demand Side Unit** or equipment necessary to the operation of the **Demand Side Unit** where such repair or maintenance cannot reasonably, in accordance with **Prudent Utility Practice**, be deferred to a period of **Scheduled Outage** or **Short Term Scheduled Outage**.
- (d) necessary to avoid an imminent risk of injury to persons or material damage to property (including the **Demand Side Unit**);
- (e) it is not lawful for the **Demand Side Unit Operator** to change its **Demand Side Unit MW Response** or to operate its **Demand Side Unit**.

SDC1.4.3.6 Changes in Availability:

- (a) Increasing: If a **Generator**, a **Generator Aggregator** or a **Demand Side Unit Operator** in respect of a **CDGU**, an **Aggregated Generating Unit**, a **Demand Side Unit**, **Energy Storage Power Station** or **Pumped Storage Plant** in relation to **Demand**, issues an **Availability Notice** increasing (from zero or otherwise) the level of **Availability** or **Demand Side Unit MW Availability** from a specified time, such notice shall be construed as meaning that:
 - (i) in the case of a **CDGU** and/or **Aggregated Generating Unit**, the **CDGU** and/or **Aggregated Generating Unit** is capable of being synchronised to the **Transmission System** or **Distribution System** at that specified time or increasing its **MW Output** at that specified time as the case may be;
 - (ii) in the case of a **CDGU** which is an **Open Cycle Gas Turbine**, the **CDGU** is capable of being started at that specified time; or
 - (iii) in the case of a **Demand Side Unit**, the **Demand Side Unit** is capable of delivering a greater **Demand Side Unit MW Response** at that specified time.
- (b) Controllable-WFPS Controllable PPM: If a **Generator** or, where relevant a **Generator Aggregator**, in respect of a Controllable-WFPS Controllable PPM, issues an **Availability Notice** increasing (from zero or otherwise) or decreasing the level of **Availability** from a specified time, such notice shall be effective from the **Trading Period** following the specified time.

SDC1.4.3.7 Decreasing: When a **CDGU** and/or Controllable-WFPS Controllable PPM is **Synchronised** to the **System** the **Generator** may have occasion to issue an

Availability Notice decreasing the level of **Availability** of the **CDGU** and/or **Controllable WFPS Controllable PPM** from a specified time. Such notice shall be construed as meaning that the **CDGU** and/or **Controllable WFPS Controllable PPM** is capable of maintaining **Load** at the level of the prevailing **Availability** until the time specified in the notice. Thereafter, the **CDGU** and/or **Controllable WFPS Controllable PPM** shall be capable of maintaining **Load** to the level which would have been achieved if a **Dispatch Instruction** had been given to reduce the **Load**. This would have occurred with effect from the specified time, at the maximum **De-Loading Rate** and/or **Ramp-Down Rate** declared for the **CDGU** and/or **Controllable WFPS Controllable PPM** as a **Technical Parameter** at such time down to the level of **Availability** specified in the new **Availability Notice**.

When a **Demand Side Unit** is providing a **Demand Side Unit MW Response** the **Demand Side Unit** may have occasion to issue an **Availability Notice** decreasing the level of **Demand Side Unit MW Availability** of the **Demand Side Unit** from a specified time. Such notice shall be construed as meaning that the **Demand Side Unit** is capable of maintaining **Demand Side Unit MW Response** at the level of the prevailing **Demand Side Unit MW Availability** until the time specified in the notice. Thereafter, the **Demand Side Unit** shall be capable of maintaining **Demand Side Unit MW Response** to the level which would have been achieved if a **Dispatch Instruction** had been given to reduce the **Demand Side Unit MW Response**. This would have occurred with effect from the specified time, at the **Maximum Ramp Down Rate** declared for the **Demand Side Unit** as a **Technical Parameter** at such time down to the level of **Demand Side Unit MW Availability** specified in the new **Availability Notice**.

SDC1.4.3.8 If an **Interconnector Owner** in respect of an **Interconnector** issues an **Availability Notice** increasing (from zero or otherwise) or decreasing the level of available transfer capacity on the **Interconnector** as a whole from a specified time, such notice shall, subject to SDC1.4.5.1(a), be effective immediately following the specified time.

SDC1.4.4 **Technical and Commercial Data Requirements**

SDC1.4.4.1 **Technical Parameters**

(a) (i) By not later than the EA1 **Gate Window Closure**, each **User** shall in respect of each:

- **CDGU;**
- **Controllable WFPS Controllable PPM;**
- **Aggregated Generating Unit,**
- **Pumped Storage Plant Demand**
- **Energy Storage Power Station Demand;** and/or
- **Demand Side Unit,**

submit to the **TSO** a **Technical Parameters Notice** in such form as the **TSO** may reasonably notify to each **User** or in the form published on the **TSO** website from time to time, containing the **Technical Parameters** to apply for the following **Trading Day**.

(ii) A **User** may satisfy this obligation by submitting the data under the **TSC**, unless the **TSO** requires, by notice in writing to the **User**, the data to be submitted to it under the **Grid Code**.

- (iii) Subsequent revisions to the **Technical Parameters Notice** may be submitted according to the technical offer data submission provisions as set out in the **TSC**. If there is a change to the data submitted under the **TSC**, the **User** shall notify the **TSO**.
- (b) Flexibility:
- (i) In the case of any **Technical Parameters** as to which the **User** should, acting in accordance with **Prudent Utility Practice**, have some flexibility either in the revision itself or in the time at which the revision is to take effect the **TSO** may, acting reasonably, suggest an amended data figure and/or an amended time at which the data figure is to take effect.
 - (ii) Insofar as it is able to do so without breaching any obligations regarding confidentiality contained either in the **TSO Licence** or in any agreement, the **TSO** shall notify the **User** of the reasons for such flexibility request in such degree of detail as the **TSO** considers reasonable in the circumstances.
 - (iii) If the **User** agrees to such suggestion (such agreement not to be unreasonably withheld) the **User** shall use reasonable endeavours to accommodate such suggestion and submit a revised **Technical Parameters Notice** accordingly. In any event, the **TSO** may require such further information on the revision as is reasonable and the **User** shall give the **TSO** such information as soon as reasonably practicable.

A **User** shall notify the **TSO** as soon as it becomes aware, acting in accordance with **Prudent Utility Practice**, that any of the data submitted under SDC1.4.4.1 changes.

SDC1.4.4.2 Additional Grid Code Characteristics Notice

The following items are required to be submitted by each **User** direct to the **TSO**:

- (a) Individual **CCGT Unit** data equivalent to the data required for a **CCGT Installation**. It shall also show any revisions to the **Technical Parameters** for each of the **CCGT Units** within it.

[Note: The term “CCGT Module” applies to the SONI Grid Code and the term “CCGT Unit” will apply to the EirGrid Grid Code.]
- (b) Different Fuels: In the case where a **CDGU** is capable of firing on different fuels, then the **Generator** shall submit an **Additional Grid Code Characteristics Notice** in respect of any additional fuel for the **CDGU**, each containing the information set out in SDC1.4.4.1 above for each fuel and each marked clearly to indicate to which fuel it applies.
- (c) *Export adjustment factors applied by the **User** in submitting data and that may be applied by the **TSO** where applicable in issuing **Dispatch Instructions** and otherwise in calculations relating to instructions in relation to the relevant **Plant** and/or **Apparatus**, between the **Generator Terminals** and the **Connection Points**.*
- (d) In the case of **Interconnector Owners**, **Interconnector** data, including but not limited to the **Availability** of **Interconnector Filters**.

- (e) In relation to each **Demand Side Unit**, the **Demand Side Unit Energy Profile** and the **Demand Side Unit MW Response Time**.
- (f) Where there is a **Ancillary Services Agreement** in place, the **Ancillary Services** which are **Available**.
- (g) The parameters listed in Appendix A Part 2 of SDC1.
- (h) A **Generator** shall submit to the **TSO** the **Operating Reserve capabilities** for each category of **Operating Reserve** defined in OC4.6.3 for each of its **CDGUs** for each **Trading Period**.

[Note: Please note that the above paragraph only applies to the EirGrid Grid Code only.]

A **User** shall notify the **TSO** as soon as it becomes aware, acting in accordance with **Prudent Utility Practice**, that any of the data submitted under SDC1.4.4.2 changes.

SDC1.4.4.3 *Not used.*

SDC1.4.4.4 **Other Relevant Data**

- (a) By not later than the EA1 **Gate Window Closure** each day, each **User** in respect of each of its **Plant**, shall in respect of the following **Trading Day** submit to the **TSO** in writing in the form set out on the **TSO** website or in such other form as the **TSO** may reasonably notify to each **User** from time to time), details in relation to the following **Trading Day** of any newly arisen special factors, including abnormal risk to loss, which in the reasonable opinion of the **User** may have a material effect on the likely **MW Output** or **Demand Side Unit MW Response** of such **Plant** (including, for a **CCGT Installation** in relation to each of the **CCGT Units** therein). The notice shall be consistent with the **User's** obligations under SDC1.4.3.2. The provisions of this paragraph also apply to **Interconnector Owners** in relation to their **Interconnector Filters**.

[Note: The term "CCGT Module" will apply to the SONI Grid Code and the term "CCGT Unit" will apply to the EirGrid Grid Code.]

- (b) Where a **CDGU** is capable of firing on different fuels, then the **Generator** shall submit details in respect of each fuel for the **CDGU**. Each set of details shall contain the information set out in (a) above for each fuel and each shall be marked clearly to indicate to which fuel it applies.

A **User**, acting in accordance with **Prudent Utility Practice**, shall notify the **TSO** as soon as it becomes aware that any of the data submitted under SDC1.4.4.4 has changed.

SDC1.4.4.5

Commercial Offer Data

- (a) Each:
- **Generator;**
 - **Energy Storage Generator;**
 - **Pumped Storage Generator;**
 - **Interconnector User;**
 - **Demand Side Unit Operator;** and
 - **Generator Aggregator,**

Shall in respect of:

Each of its **CDGUs;**

Each of its **Energy Storage Power Station Demand;**

Each of its **Pumped Storage Plant Demand;**

Each of its **Interconnector Units;**

Each of its **Demand Side Units;** and

Its **Aggregated Generating Units,**

submit to the TSO, either directly or by means of an Intermediary on its behalf, Commercial Offer Data by the Gate Window Closures for the corresponding Trading Windows in accordance with the TSC. If no new Commercial Offer Data is submitted, the last accepted data will be used.

- (b) Each **Generator** shall in respect of each of its **Energy Limited Generating Units** submit an **Energy Limit** as well as the **Commercial Offer Data** by **Gate Window Closure** for the corresponding **Trading Window**. If no new data is submitted, the last accepted data will be used.
- (c) Each **Pumped Storage Plant** will, with respect to its **Pumped Storage Plant Demand**, submit its **Target Reservoir Level** by **Gate Window Closure** for the corresponding **Trading Window**. If no new data is submitted, the last accepted data will be used.
- (d) Each **Energy Storage Power Station** will, with respect to its **Energy Storage Power Station Demand**, submit its **Target Charge Level** by **Gate Window Closure** for the following **Trading Window**. If no new data is submitted, the last accepted data will be used.

The **TSO** may require, by notice to the relevant **User**, the data referred to at SDC1.4.4.5 (a) to (c) to be submitted to it directly under the **Grid Code**. All data items submitted under this SDC1.4.4.5 are to be at levels of **MW Output** at the **Connection Point**.

SDC1.4.5

Revisions/Re-declarations to data

SDC1.4.5.1

Availability

- (a) **Availability:** A **User** may, subject to SDC1.4.3 and as provided in this SDC1, make revisions to the **Availability Notice** submitted to the **TSO** under SDC1.4.1.1 at any time after submission of the **Availability Notice** in accordance with its obligations to make the **Unit Available** under SDC1.4.3 by submission by **the Electronic Interface** of a revised **Availability Notice** which shall be in the form set out on the **TSO** website or in such other form as the **TSO** may reasonably notify to each **User** from time to time.

- (b) In the event that the **TSO** submits a **Post Event Notice** under *OC10* in relation to any part of the period covered by the **Availability Notice** at any time after submission of the **Availability Notice**, the **User** shall be deemed to have submitted a revised **Availability Notice** consistent with such **Post Event Notice**.
- (c) The revisions to the **Availability Notice** may include revisions of the levels of **Availability** in the **CCGT Installation Matrix** reflecting the revised **Availability**.
- (d) Additional Availability Notice: A **User** may, subject to SDC1.4.3 and to the provisions of this SDC1, make revisions to the **Additional Grid Code Availability Notice** submitted to the **TSO** under SDC1.4.2 at any time after the submission of the **Additional Grid Code Availability Notice** in accordance with its obligations to make the Unit **Available** under SDC1.4.3 by submission by the **Electronic Interface** of a revised **Additional Grid Code Availability Notice**. The Notice shall be in the form set out on the **TSO** website or in such other form as the **TSO** may reasonably notify each **User** from time to time.

SDC1.4.5.2

Technical Parameters and Additional Grid Code Characteristics

- (a) Technical Parameters: If any of the data submitted to the **TSO** under SDC1.4.4.1 and SDC1.4.4.4 changes, a **User** shall, subject to SDC1.4.3, (in the case of data submitted under SDC1.4.4.1 by means of a **Technical Parameters Notice**) make revisions to such data. The **User** shall notify the **TSO** of any revisions to any previously revised data by submitting by the **Electronic Interface** a revised **Technical Parameters Notice** in the form set out on the **TSO** website or in such other form as the **TSO** may reasonably notify to each **User** from time to time. The **User** must notify the **TSO** of any new **Other Relevant Data** of which it becomes aware at any time after any original submission, in writing.
- (b) Additional Grid Code Characteristics: A **User** may make revisions to the **Additional Grid Code Characteristics Notice** submitted to the **TSO** under SDC1.4.4.2 at any time after the submission of the **Additional Grid Code Characteristics Notice** by submitting by **Electronic Interface** a revised **Additional Grid Code Characteristics Notice**. The notice shall be in the form set out on the **TSO** website or in such other form as the **TSO** may reasonably notify to each **User** from time to time.
- (c) **Energy Limits for Hydro Units**: A **Generator** in respect of its **Hydro Units** shall resubmit **Energy Limits** on the **Trading Day** regardless of whether the **Energy Limits** have changed since the EA1 **Gate Window Closure**. Revised **Energy Limits for Hydro Units** may be submitted at any time up until 18.00 hours on the **Trading Day** in writing per unit basis.

SDC1.4.5.3

The **TSO** shall, insofar as it is reasonably able, take account of such revisions or notifications submitted under SDC1.4.5 for **Scheduling** and **Dispatch** purposes.

SDC1.4.6

- (a) Defaults:
 - (i) Insofar as any data submitted or deemed to have been submitted on any particular day in any **Availability Notice**, **Technical Parameters Notice** (such notice not being relevant to

an **Interconnector Owner**), or notice of **Other Relevant Data** or any revision thereto is inconsistent with any other data in any other such notice, then the most recently submitted data which, if substituted for the inconsistent data, would make the data in such notices consistent, shall apply for the next following **Trading Window** or any other values that the **TSO** may reasonably deem appropriate.

- (ii) Insofar as an **Availability Notice** is not submitted, the **User** shall be deemed to have submitted an **Availability Notice** by **Gate Closure** stating that the **Availability** of the relevant **CDGU**, ~~Controllable WFPS~~ **Controllable PPM**, **Demand Side Unit** and/or the **Aggregated Generating Units** for the whole of the following **Trading Window** will be the level of **Availability** and **Operating Mode** declared in respect of the final **Trading Period** of the current **Trading Window** or any other values that the **TSO** may reasonably deem appropriate.
 - (iii) Insofar as not submitted or revised, the applicable **Standing Technical Offer Data** for **Technical Parameters** shall apply for the next following **Trading Day**.
 - (iv) Insofar as not submitted or revised, the last notice relating to **Other Relevant Data** to have been submitted shall apply for the next following **Trading Day**.
 - (v) In respect of **Hydro Units**, the **Energy Limit** that applied to the previous **Trading Day** will be used.
- (b) As a general requirement, the **User** shall ensure that the data in any **Availability Notice**, **Technical Parameters Notice**, or notice of any **Other Relevant Data** or any revision thereto is consistent with its obligations under SDC1.4.3.2 and SDC1.4.3.4.

SDC1.4.7 Form of Submission

- (a) Where this SDC1 requires a **User** to submit a notice, it may instead of submitting it in writing, submit the information required in such a notice (which information shall be supplied in full) by telephone subject to the **TSO's** prior consent (identifying unambiguously the type of notice which is thereby being submitted).
- (b) The individual who is giving the notice by telephone on behalf of the **User** shall firstly specify the time at which the notice is being given, then identify himself and ask the individual receiving the notice on behalf of the **TSO** also to identify himself. The information required by the notice shall then be given, including (without limitation) the identity of the **CDGU**, ~~Controllable WFPS~~ **Controllable PPM**, **Energy Storage Power Station Demand**, **Aggregated Generating Unit**, **Pumped Storage Plant** and **Demand Side Unit** to which the notice relates.
- (c) The notice shall then be confirmed by facsimile transmission or by any electronic means as agreed with the **TSO** as soon as possible thereafter (and in any event be sent to the **TSO** within 2 hours). Where a facsimile is so sent by way of confirmation, it shall state clearly that it is in confirmation of a notice already given by telephone and shall state the exact time at which the notice was given by telephone.

SDC1.4.8 Compilation of the Indicative Operations Schedule

SDC1.4.8.1 An **Indicative Operations Schedule** will be compiled daily by the **TSO** in conjunction with the **Other TSO** as further provided in this SDC1.4.8 as a statement of which **CDGUs** and/or ~~Controllable WFPS~~ **Controllable PPM** and/or transfers across any **Interconnector** and/or **Demand Side Units** and/or **Pumped Storage Plant Demand**, **Energy Storage Power Station Demand** and/or **Aggregated Generating Units** and equivalent units in *Northern Ireland* may be required to operate and their expected **MW Output** for the next following **Trading Day**.

SDC1.4.8.2 Merit Order

Subject as provided below, a **Merit Order** will be compiled by the **TSO** (in conjunction with the **Other TSO**) for each **Trading Window** from the **Price Quantity Pairs**, **Start-Up Cost**, **Shutdown Cost** and **No-Load Cost** (which together shall be known as the “**Price Set**”) and, subject as provided in this SDC1, used to determine which of the **CDGUs**, ~~Controllable WFPSs~~ **Controllable PPMs**, **Pumped Storage Plant Demand**, **Energy Storage Power Station Demand**, **Demand Side Units**, **Aggregated Generating Units** or **Interconnector** tranche to **Schedule** and **Dispatch** in relation to their **Price Sets**. The **Merit Order** will be on the basis of ascending prices so that the **CDGU**, ~~Controllable WFPS~~ **Controllable PPM**, **Pumped Storage Plant Demand**, **Energy Storage Power Station Demand**, **Demand Side Unit**, **Aggregated Generating Unit Price Set** or **Interconnector tranche Price Set** at the head of the **Merit Order** will be that which has the lowest **Incremental Price** per **MWh**, and that at the foot of the **Merit Order** shall be the one with the highest **Incremental Price** per **MWh**. Each **CDGU**, ~~Controllable WFPS~~ **Controllable PPM**, **Pumped Storage Plant Demand**, **Energy Storage Power Station Demand**, **Demand Side Unit**, **Aggregated Generating Units** and/or **Interconnector** tranche shall appear in the **Merit Order** for each **Price Set** submitted.

SDC1.4.8.3 In compiling the **Indicative Operations Schedule** in conjunction with the **Other TSO**, the **TSO** will take account of and give due weight to the following factors (and the equivalent factors on the **Other Transmission System** will be so treated separately by the **Other TSO**):

- (i) **Transmission System** constraints from time to time, as determined by the **TSO**;
- (ii) Reserve constraints from time to time, as determined by the **TSO**;
- (iii) the need to provide an **Operating Margin** (by using the various categories of reserve as specified in *OC4.6 and CC7.3.1.1* (as the case may be), as determined by the **TSO** acting in conjunction with the **Other TSO**;
- (iv) **Transmission System** stability considerations;
- (v) the level of **MW Output** and availability covered by **Non Centrally Dispatched Generating Units**, by **Plant** subject to **Priority Dispatch** and by **Controllable WFPS**;
- (vi) the **Target Reservoir Levels** for **Pumped Storage** taken against the initial conditions at 0600 hours the previous day;
- (vii) the **Target Charge Levels** for **Energy Storage Power Stations** taken against the initial conditions at 0600 hours the previous day;
- ~~(vii)~~ (vii) the **Energy Limits** for **Hydro Units**;

- ~~(viii)~~ (ix) in respect of all **Plant**, the values of their **Technical Parameters** registered under this SDC1 and other information submitted under SDC1.4.4.4;
- ~~(ix)~~ (x) the **Start-Up Cost** of each **CDGU** and/or ~~**Controllable-WFPS**~~ **Controllable PPM** and the **Shutdown Cost** of each **Demand Side Unit**;
- ~~(x)~~ (xi) the requirements, as determined by the **TSO**, for **Voltage Control** and **Mvar** reserves;
- ~~(xi)~~ (xii) **CDGU** and/or ~~**Controllable-WFPS**~~ **Controllable PPM** stability, as determined by the **TSO**;
- ~~(xii)~~ (xiii) other matters to enable the **TSO** to meet its **Licence Standards** and the **Other TSO** to meet its equivalent;
- ~~(xiii)~~ (xiv) the requirements as determined by the **TSO**, for maintaining **Frequency Control**;
- ~~(xiv)~~ (xv) **Monitoring** and/or **Testing** and/or **Investigations** to be carried out, or being carried out, under *OC10* (as the case may be), Testing to be carried out, or being carried out, at the request of a User under *OC8* and/or **Commissioning Testing** under the CC;
- ~~(xv)~~ (xvi) **System Tests, Operational Tests and Commissioning Tests**;
- ~~(xvi)~~ (xvii) the inability of any **CDGU** and/or ~~**Controllable-WFPS**~~ **Controllable PPM** to meet its full reserve capability;
- ~~(xvii)~~(xviii) **Inter-jurisdictional Tie Line** limits;
- ~~(xviii)~~ (xix) other facts as may be reasonably considered by the **TSO** to be relevant to the **Indicative Operations Schedule**;
- ~~(xix)~~ (xx) the inflexible characteristics as declared by the **Generator** and abnormal risks;
- ~~(xx)~~ (xxi) losses on the **Transmission System** and on the **Other Transmission System**;
- ~~(xxi)~~ (xxii) **Nomination Profiles** where relevant;
- ~~(xxii)~~ (xxiii) requirements within any **Constrained Group**;
- ~~(xxiii)~~ (xxiv) the fact that the **Interconnector** tranches in the unconstrained **Indicative Market Schedule** cannot be changed in the **Indicative Operations Schedule**;

SDC1.4.8.4

Taking account of and applying the factors referred to in SDC1.4.8.3, the **Indicative Operations Schedule** shall be compiled by the **TSO** in conjunction with the **Other TSO** to **Schedule** such **CDGUs**, ~~**Controllable-WFPS**~~ **Controllable PPM**, **Pumped Storage Plant Demand**, **Energy Storage Power Station Demand**, **Demand Side Units**, **Aggregated Generating Units** and/or such **Interconnector** tranches, and equivalent units or tranches of equivalent units in *Northern Ireland*, which have been declared **Available** in an **Availability Notice** (and the equivalents on the **Other Transmission System**):

- (i) in accordance with the **Merit Order**, starting with the **CDGU**, ~~**Controllable-WFPS**~~ **Controllable PPM**, **Pumped Storage Plant Demand**, **Energy Storage Power Station Demand**, **Demand Side**

Units and/or **Aggregated Generating Unit Price Set**, and the **Price Set** for equivalent units in *Northern Ireland*, together with **Interconnector** tranches in the unconstrained **Indicative Market Schedule** at the head of the **Merit Order**;

- (ii) as will in aggregate (after taking into account electricity delivered other than from **CDGUs**, ~~**Controllable—WFPSs**~~ **Controllable PPMs**, **Aggregated Generating Units**, and/or **Interconnector** tranches and variation in **Demand** from **Pumped Storage Plant Demand**, **Energy Storage Power Station Demand** and **Demand Side Units**) be sufficient to match at all times (to the extent possible having regard to the **Availability** or **Demand Side Unit MW Availability** of **CDGUs**, ~~**Controllable—WFPSs**~~ **Controllable PPMs**, **Pumped Storage Plant Demand**, **Energy Storage Power Station Demand**, **Demand Side Units**, **Aggregated Generating Units** and **Interconnector** tranches) the forecast aggregated **Demand** (derived under OC1 of the **Grid Code** and the **Other Grid Code**) together with such margin of reserve as the **TSO** working in conjunction with the **Other TSO** shall consider to be appropriate; and
- (iii) as will in aggregate be sufficient to match minimum forecast **Demand** levels together with a sufficient **Minimum Demand Regulation**.

The taking account of and application of the factors in SDC1.4.8.3 will mean that, in general, the strict **Merit Order** may not necessarily be followed.

SDC1.4.8.5 After the completion of the **Scheduling** process, but before the issue of **Indicative Operations Schedule**, the **TSO** may consider it necessary to make adjustments to the **MW Output** as determined by the **Scheduling** process. Such adjustments could be made necessary by any of the following factors (and the equivalent factors on the **Other Transmission System** which will be so dealt with separately by the **Other TSO**):

- (a) changes to **Availability** or **Demand Side Unit MW Availability** and/or **Technical Parameters** of **CDGUs** and/or ~~**Controllable—WFPS**~~ **Controllable PPM** and/or **Aggregated Generating Units** and/or **Demand Side Units** notified to the **TSO** after the commencement of the **Scheduling** process;
- (b) changes to **Demand** forecasts on the Island of Ireland;
- (c) changes to ~~wind-power~~ **resource** forecasts on the Island of Ireland;
- (d) changes to **Transmission System** constraints, emerging from the necessarily iterative process of **Scheduling** and network security assessment;
- (e) changes to **CDGU** and/or ~~**Controllable—WFPS**~~ **Controllable PPM** requirements following notification to the **TSO** of the changes in capability of a **Generator** to provide a **Special Action** as described in SDC2;
- (f) changes to **CDGU** and/or ~~**Controllable—WFPS**~~ **Controllable PPM** requirements within **Constrained Groups**, following re-appraisal of **System Demand** forecasts on the Island of Ireland within that **Constrained Group**;
- (g) changes to any conditions which in the reasonable opinion of the **TSO**, would impose increased risk to the **Transmission System** and would therefore require an increase in the **Operating Margin**;

- (h) known (or emerging) limitations and/or deficiencies of the **Scheduling** process.

SDC1.4.8.6 When:

- (a) adverse weather is anticipated;
- (b) there is a high risk to the whole or part of the **Transmission System** and/or the **Other Transmission System**;
- (c) **Demand Control** has been instructed by the **TSO**; or
- (d) a **Total Shutdown** or **Partial Shutdown** exists;

these factors may mean that a **CDGU**, ~~Controllable WFPS~~ **Controllable PPM**, **Pumped Storage Plant Demand**, **Energy Storage Power Station Demand**, **Demand Side Unit**, **Aggregated Generating Unit** and/or **Interconnector** transfers is/are chosen other than in accordance with the **Merit Order** to a greater degree than would be the case when merely taking into account and giving due weight to the factors listed in SDC1.4.8.3 in order to seek to maintain the integrity of the **Transmission System**.

SDC1.4.8.7

- (a) The **Synchronising** and **De-Synchronising** times (and, in the case of **Pumped Storage Plant Demand** and **Energy Storage Power Station Demand**, the relevant effective time) shown in the **Indicative Operations Schedule** are indicative only and it should be borne in mind by **Users** that the **Dispatch Instructions** could reflect more or different **CDGU**, **Aggregated Generating Unit** and/or ~~Controllable WFPS~~ **Controllable PPM**, **Pumped Storage Plant Demand**, **Energy Storage Power Station Demand** and/or **Aggregate Generating Unit** requirements than in the **Indicative Operations Schedule**. The **TSO** may issue **Dispatch Instructions** in respect of any **CDGU** and/or **Aggregated Generating Unit**, ~~Controllable WFPS~~ **Controllable PPM**, **Pumped Storage Plant Demand**, **Energy Storage Power Station Demand** or **Aggregated Generating Unit** which has not declared an **Availability** or **Demand Side Unit MW Availability** of 0 MW in an **Availability Notice**. **Users** with **CDGUs** and/or **Aggregated Generating Units**, ~~Controllable WFPS~~ **Controllable PPM**, **Pumped Storage Plant Station Demand** or **Energy Storage Power Station Demand** shall ensure that their units are able to be **Synchronised**, or in the case of **Pumped Storage Plant Demand**, used at the times **Scheduled**, but only if so **Dispatched** by the **TSO** by issue of a **Dispatch Instruction**. **Users** shall, as part of a revision to the **Technical Parameters**, indicate to the **TSO** the latest time at which a **Dispatch Instruction** is required to meet the scheduled **Synchronising** time or in the case of **Pumped Storage Plant Demand** or **Energy Storage Power Station Demand**, the **Scheduled** relevant effective time.
- (b) The provisions of SDC1.4.8.7(a) shall apply to **Demand Side Units** with the exception that reference to relevant effective time shall be read as a reference to **Demand Side Unit NoticeTime**.

SDC1.4.8.8

Content of **Indicative Operations Schedule**

The information contained in the **Indicative Operations Schedule** will indicate, where appropriate, on an individual **CDGU**, ~~Controllable WFPS~~ **Controllable PPM**, **Pumped Storage Plant Demand**, **Energy Storage Power Station Demand**, **Demand Side Unit** and/or **Aggregated Generating Units** basis, the period and **Loading** for which it is **Scheduled** during the following **Trading Day**. In the case of a **CDGU** which is capable of firing on two different fuels, it will also indicate the fuel

for which it is **Scheduled** during the following **Trading Day**. If no fuel is contained in the **Indicative Operations Schedule**, then the most recently specified fuel shall be treated as having been indicated.

SDC1.4.8.9 Issue of Indicative Operations Schedule

- (a) The **Indicative Operations Schedule** associated with the EA2 **Trading Window** will be published for access by **Users** by 1600 hours each day preceding the relevant **Trading Window**, and the **Indicative Operations Schedule** associated with the within-day WD1 **Trading Window** will be published for access by **Users** by 1330 hours each day on the relevant **Trading Day**, provided that all the necessary information from the **Users** was made available by not later than **Gate Window Closure**. However, if on any occasion the **TSO** is unable to meet these times, the **TSO** also reserves the right to extend the timescale for the issue of the **Indicative Operations Schedules** to the extent necessary. Following the issue of the **Indicative Operations Schedule** preceding the relevant **Trading Window**, the **TSO** may issue revised **Indicative Operations Schedules** up until one hour before the start of the **Trading Window**.
- (b) The **TSO** may issue **Dispatch Instructions** to **Users** in respect of **CDGUs**, ~~Controllable WFPSs~~ **Controllable PPMs**, **Pumped Storage Plant Demand**, **Energy Storage Power Station Demand** and/or **Demand Side Units** and/or **Aggregated Generating Units** and/or **Interconnector** transfers before the issue of the **Indicative Operations Schedule** for the **Trading Day** to which the **Dispatch** instruction relates if the length of **Notice to Synchronise** the relevant **CDGUs** and/or ~~Controllable WFPSs~~ **Controllable PPMs**, **Pumped Storage Plant Demand**, **Energy Storage Power Station Demand** and/or **Demand Side Unit** and/or **Aggregated Generating Unit** requires the **Dispatch** instruction to be given at that time. When the length of the time required for **Notice to Synchronise** is within 30 minutes of causing the **CDGU** and/or ~~Controllable WFPSs~~ **Controllable PPMs** and/or **Pumped Storage Plant Demand** and/or **Energy Storage Power Station Demand** to be unable to meet the indicative **Synchronising** time in the **Indicative Operations Schedule** or a subsequent indicative **Synchronising** time and no **Dispatch Instruction** has been received, the **Generator** shall inform the **TSO** without delay.

SDC1.4.8.10 Regulation

It is a requirement for running the **Transmission System** that all **Synchronised CDGUs** and/or ~~Controllable WFPSs~~ **Controllable PPMs** shall at all times be capable of reducing **MW Output** sufficient to allow a sufficient **Regulating Margin** for adequate **Frequency Control**. The **TSO** will monitor the **MW Output** data of the **Indicative Operations Schedule** against forecast of **System Demand** on the Island of Ireland to see whether the level of regulation for any period is sufficient, and may take any shortfall into account in **Scheduling** and **Dispatch**.

SDC1.4.8.11 Data Requirements

SDC1 Appendix A Part 1 sets out the **Technical Parameters** for which values are to be supplied by a **User** in respect of each of its **CDGUs** and/or ~~Controllable WFPSs~~ **Controllable PPMs** and/or **Pumped Storage Plant Demand** and/or **Energy Storage Power Station Demand** and/or **Demand Side Units** and/or **Aggregated Generating Units** by not later than **Gate Closure** on the day prior to the **Trading Day**.

SDC1 Appendix A Part 2 sets out the additional data items required in respect of an **Additional Grid Code Characteristics Notice**.

SDC1 – APPENDIX A

Part 1. Technical Parameters

[Note: The factors applicable to CDGUs below 10 MW apply to the EirGrid Grid Code only.]

Technical Parameter	CDGU				Control WFPS	DSU		Agg. Gen	CDGU <10 MW	ESPS Demand	Pump Storage Demand
	Thermal	Hydr/ En Ltd	Disp. WFPS PPM	Pump S Gen		Indiv. id uat Demand Site	Agg. reg ated Demand Sites				
					-				-	-	-
Block Load Cold	✓	✓	✓	✓	✓				✓		
Block Load Hot	✓								✓		
Block Load Warm	✓								✓		
Charging Capacity			✓ ESPS Gen Only							✓	
Demand Side Unit Energy Profile						✓	✓				
Demand Side Unit MW Availability						✓	✓				
Demand Side Unit MW Response Time						✓	✓				
Demand Side Unit Notice Time						✓	✓				
Deload Break Point	✓	✓	✓	✓	✓				✓		
De-Loading Rate 1	✓	✓	✓	✓	✓				✓		
De-Loading Rate 2	✓	✓	✓	✓	✓				✓		
Dwell Time Up 1	✓	✓	✓	✓	✓				✓		
Dwell Time Up 2	✓	✓	✓	✓	✓				✓		
Dwell Time Up 3	✓	✓	✓	✓	✓				✓		
Dwell Time Down 1	✓	✓	✓	✓	✓				✓		
Dwell Time Down 2	✓	✓	✓	✓	✓				✓		
Dwell Time Down 3	✓	✓	✓	✓	✓				✓		
Dwell Time Up Trigger Point 1	✓	✓	✓	✓	✓				✓		
Dwell Time Up Trigger Point 2	✓	✓	✓	✓	✓				✓		
Dwell Time Up Trigger Point 3	✓	✓	✓	✓	✓				✓		
Dwell Time Down Trigger Point 1	✓	✓	✓	✓	✓				✓		
Dwell Time Down Trigger Point 2	✓	✓	✓	✓	✓				✓		
Dwell Time Down Trigger Point 3	✓	✓	✓	✓	✓				✓		
End Point of Start Up Period	✓	✓	✓	✓	✓				✓		
Energy Limit		✓									
Energy Limit Factor		✓									
Energy Limit Start		✓									
Energy Limit Stop		✓									
Forecast Minimum Output Profile				✓						✓	✓
Forecast Minimum Generation Profile	✓	✓	✓	✓					✓		
Demand Side Unit MW Response Time						✓	✓				

Technical Parameter	CDGU				Control WFPS	DSU		Agg. Gen	CDGU <10 MW	ESPS Demand	Pump Storage Demand
	Thermal	Hydr/ En Ltd	Disp. WFPS PPM	Pump S Gen		Indiv. id ual Demand Site	Agg. reg ated Demand Sites				
Load Up Break Point Cold (1)	✓	✓	✓	✓	✓				✓		
Load Up Break Point Cold (2)	✓	✓	✓	✓	✓				✓		
Load Up Break Point Hot (1)	✓								✓		
Load Up Break Point Hot (2)	✓								✓		
Load Up Break Point Warm (1)	✓								✓		
Load Up Break Point Warm (2)	✓								✓		
Loading Rate Cold (1)	✓	✓	✓	✓	✓				✓		
Loading Rate Cold (2)	✓	✓	✓	✓	✓				✓		
Loading Rate Cold (3)	✓	✓	✓	✓	✓				✓		
Loading Rate Hot (1)	✓								✓		
Loading Rate Hot (2)	✓								✓		
Loading Rate Hot (3)	✓								✓		
Loading Rate Warm (1)	✓								✓		
Loading Rate Warm (2)	✓								✓		
Loading Rate Warm (3)	✓								✓		
Max Ramp Down Rate (shall be a number greater than zero)						✓	✓				
Max Ramp Up Rate (shall be a number greater than zero)						✓	✓				
Maximum Charge Capacity			✓ ESPS Gen Only							✓	
Maximum Down Time						✓	✓				
Maximum Generation / Registered Capacity	✓	✓	✓	✓	✓				✓		
Maximum On Time	✓	✓	✓	✓	✓				✓		
Maximum Storage Capacity				✓							
Minimum Charge Capacity			✓ ESPS Gen Only							✓	
Minimum Down Time						✓	✓				
Minimum Generation	✓	✓	✓	✓	✓				✓		
Minimum off time	✓	✓	✓	✓	✓				✓		
Minimum on time	✓	✓	✓	✓	✓				✓		
Minimum Storage Capacity				✓							✓✓
(Other relevant technical parameters)	✓	✓	✓	✓	✓			✓	✓		
Pumping capacity				✓							✓
Ramp Down Break Point 1	✓	✓	✓	✓	✓			✓	✓		
Ramp Down Break Point 2	✓	✓	✓	✓	✓			✓	✓		
Ramp Down Break Point 3	✓	✓	✓	✓	✓			✓	✓		
Ramp Down Break Point	✓	✓	✓	✓	✓			✓	✓		

Technical Parameter	CDGU				Control WFPS	DSU		Agg. Gen	CDGU <10 MW	ESPS Demand	Pump Storage Demand
	Thermal	Hydr/ En Ltd	Disp. WFPS PPM	Pump S Gen		Indiv. id ual Demand Site	Agg. reg ated Demand Sites				
4					-				-	-	-
Ramp Down Rate 1	✓	✓	✓	✓	✓			✓	✓		
Ramp Down Rate 2	✓	✓	✓	✓	✓			✓	✓		
Ramp Down Rate 3		✓	✓	✓	✓			✓			
Ramp Down Rate 4	✓	✓	✓	✓	✓			✓	✓		
Ramp Down Rate 5	✓	✓	✓	✓	✓			✓	✓		
Ramp Up Break Point 1	✓	✓	✓	✓	✓			✓	✓		
Ramp Up Break Point 2	✓	✓	✓	✓	✓			✓	✓		
Ramp Up Break Point 3	✓	✓	✓	✓	✓			✓	✓		
Ramp Up Break Point 4	✓	✓	✓	✓	✓			✓	✓		
Ramp Up Rate 1	✓	✓	✓	✓	✓			✓	✓		
Ramp Up Rate 2	✓	✓	✓	✓	✓			✓	✓		
Ramp Up Rate 3	✓	✓	✓	✓	✓			✓	✓		
Ramp Up Rate 4	✓	✓	✓	✓	✓			✓	✓		
Ramp Up Rate 5	✓	✓	✓	✓	✓			✓	✓		
Short Term Maximisation Capability	✓	✓	✓	✓	✓				✓		
Soak Time Cold (1)	✓	✓	✓	✓	✓				✓		
Soak Time Cold (2)	✓	✓	✓	✓	✓				✓		
Soak Time Hot (1)	✓								✓		
Soak Time Hot (2)	✓								✓		
Soak Time Trigger Point Cold (1)	✓	✓	✓	✓	✓				✓		
Soak Time Trigger Point Cold (2)	✓	✓	✓	✓	✓				✓		
Soak Time Trigger Point Hot (1)	✓								✓		
Soak Time Trigger Point Hot (2)	✓								✓		
Soak Time Trigger Point Warm (1)	✓								✓		
Soak Time Trigger Point Warm (2)	✓								✓		
Soak Time Warm (1)	✓								✓		
Soak Time Warm (2)	✓								✓		
Synchronous Start-Up Time Cold	✓	✓	✓	✓	✓				✓		
Synchronous Start-Up Time Hot	✓	✓	✓	✓	✓				✓		
Synchronous Start-Up Time Warm	✓								✓		
Target Charge Level Percentage			✓ ESPS Gen Only							✓	
Target Reservoir Level Percentage				✓							✓
Start of Restricted Range 1	✓	✓	✓	✓	✓				✓		
End of Restricted Range 1	✓	✓	✓	✓	✓				✓		
Start of Restricted Range 2	✓	✓	✓	✓	✓				✓		
End of Restricted Range 2	✓	✓	✓	✓	✓				✓		

[Part 2. Additional data items required in an Additional Grid Code Characteristics Notice]

Table (i)

Variable	Applies to
Declared POR	CDGUs, excluding Dispatchable WFPSs PPMs
Declared SOR	CDGUs, excluding Dispatchable WFPSs PPMs
Declared TOR1	CDGUs, excluding Dispatchable WFPSs PPMs
Declared TOR2	CDGUs, excluding Dispatchable WFPSs PPMs
Declared Replacement Reserve	CDGUs, excluding Dispatchable WFPSs PPMs
Minimum MW for POR	CDGUs, excluding Dispatchable WFPSs PPMs
Minimum MW for SOR	CDGUs, excluding Dispatchable WFPSs PPMs
Minimum MW for TOR1	CDGUs, excluding Dispatchable WFPSs PPMs
Minimum MW for TOR2	CDGUs, excluding Dispatchable WFPSs PPMs
Minimum MW for Replacement Reserve	CDGUs, excluding Dispatchable WFPSs PPMs
POR Decrement Rate	CDGUs, excluding Dispatchable WFPSs PPMs
SOR Decrement Rate	CDGUs, excluding Dispatchable WFPSs PPMs
TOR1 Decrement Rate	CDGUs, excluding Dispatchable WFPSs PPMs
TOR2 Decrement Rate	CDGUs, excluding Dispatchable WFPSs PPMs
Replacement Reserve Decrement Rate	CDGUs, excluding Dispatchable WFPSs PPMs
Governor Droop	CDGUs, excluding Dispatchable WFPSs PPMs

Table (ii)

Black Start Capability (yes/no)	CDGUs, excluding Dispatchable WFPSs PPMs
Declared Reactive Power (Consumption)	CDGUs, excluding Dispatchable WFPSs PPMs
Declared Reactive Power (Production)	CDGUs, excluding Dispatchable WFPSs PPMs
Correction Factor (Mvar consumption)	CDGUs, excluding Dispatchable WFPSs PPMs
Correction Factor (Mvar Production)	CDGUs, excluding Dispatchable WFPSs PPMs
Export Adjustment Factor 1	CDGUs, excluding Dispatchable WFPSs PPMs
Export Adjustment Factor 2	CDGUs, excluding Dispatchable WFPSs PPMs
Unit Loss Factor	CDGUs, excluding Dispatchable WFPSs PPMs

SDC2 SCHEDULING AND DISPATCH CODE NO.2

CONTROL SCHEDULING AND DISPATCH

SDC2.1 INTRODUCTION

SDC2.1.1 SEM Provisions

- (a) This Scheduling and Dispatch Code No. 2 ("SDC2") forms part of the **Sections under Common Governance** of the **Grid Code**. The **Sections under Common Governance** are those parts of the **Grid Code** which are under common governance in both the **Grid Code** and the **Other Grid Code**.
- (b) The form of this SDC2 is similar to the SDC2 in the **Other Grid Code**. Differences relate to references to relevant power systems and related terms. Where there is a difference between a provision in this **Grid Code** and an equivalent provision in the **Other Grid Code**, the wording in question is shaded in grey. In addition, those parts of this SDC2 that are not part of the **Other Grid Code** are shaded in grey in this SDC2. Differences between the form of this SDC2 and the SDC2 in the **Other Grid Code** are summarised in Annex 1 to this SDC2.
- (c) This SDC2 is intended to work in conjunction with other documents, including the **Trading and Settlement Code ("TSC")**. The provisions of the **Grid Code** and the **Other Grid Code** will take precedence over the **TSC**. The **TSC** is the document under which the principal elements of the market for electricity operate. Every **User** which trades in electricity above certain minimum thresholds is required to be a party to the **TSC**. The **Market Operator** is a party to the **TSC**, as is the **TSO** and the **Other TSO**.
- (d) The obligation to submit data in relation to some of the information required to be provided to the **TSO** by this SDC2 may be fulfilled by **Users** where such information submitted under the **TSC** by a **User** or by an **Intermediary** on behalf of **Users** is then provided to the **TSO** by the **Market Operator** under the provisions of the **TSC**, as further provided in this SDC2. The **TSO** may require **Users** to verify or update data received by it via the **Market Operator**.
- (e) Further provisions dealing with the **Sections under Common Governance** are contained in the **General Conditions**.

SDC2.1.2 SDC2 sets out the procedure for the **TSO** to issue **Dispatch Instructions** to:-

- (a) **Generators** in respect of their **CDGUs** (which for the avoidance of doubt comprise, **Generating Units** subject to **Central Dispatch**, **CCGT Installations**, **Hydro Units**, **Pumped Storage Generation** and **Dispatchable ~~WFPSs~~ PPMs**);
- (b) **Pumped Storage Generators** in respect of their **Pumped Storage Plant Demand**;
- (c) **Energy Storage Generators** in respect of their **Energy Storage Power Station Demand**;
- ~~(e)~~ (d) **Interconnector Owners** in respect of their **Interconnectors**;

- ~~(d)~~ (e) **Demand Side Unit Operators** in respect of their **Demand Side Units**; and
- ~~(e)~~ (f) **Generator Aggregators** in respect of their **Aggregated Generating Units**.

~~Controllable WFPSs~~ **Controllable PPMs** are not currently subject to **Dispatch Instructions**.

SDC2.2 OBJECTIVE

The procedure for the issue of **Dispatch Instructions** by the **TSO**, is intended to enable (as far as possible) the **TSO** to match continuously **CDGU, Demand Side Unit, Aggregated Generating Units** output (or reduction as the case may be) and/or **Interconnector** transfers to **Demand**, and thereby in conjunction with the **Other TSO**, the demand on the Island of Ireland, by utilising the **Merit Order** derived pursuant to SDC1 and the factors to be taken into account listed there and by taking into account any **NCDGU MW Output** in both cases together with an appropriate margin of reserve, whilst maintaining (so far as possible) the integrity of the **Transmission System** together with the security and quality of supply (with the **Other TSO** having a similar objective with regard to its **Transmission System**).

SDC2.3 SCOPE

SDC2 applies to the **TSO**, and:-

- (a) **Generators** with regard to their **CDGUs**;
- (b) **Pumped Storage Generators** with regard to their **Pumped Storage Plant Demand**;
- (c) **Energy Storage Generators** with regard to their **Energy Storage Power Station Demand**;
- ~~(d)~~ (d) **Interconnector Owners** with regard to their **Interconnectors**;
- ~~(e)~~ (e) **Demand Side Unit Operators** in relation to their **Demand Side Units**; and
- ~~(f)~~ (f) **Generator Aggregators** in respect of their **Aggregated Generating Units**.

Each of which (other than the **TSO**) is a “**User**” under this SDC2.

SDC2.4 PROCEDURE

SDC2.4.1 Information Used

SDC2.4.1.1 The information which the **TSO** shall use in assessing which **CDGU, Demand Side Unit, Interconnector** transfers, **Pumped Storage Plant Demand** and/or **Energy Storage Power Station Demand** and/or **Aggregated Generating Units** to **Dispatch**, will be:

- (a) the **Availability Notices**;
- (b) the **Merit Order** as derived under SDC1;

- (c) the other factors to be taken into account under SDC1 and which were used by the **TSO** to compile the **Indicative Operations Schedule**; and
- (d) the:
 - (i) **Technical Parameters**;
 - (ii) **Additional Grid Code Characteristics Notices**;
 - (iii) **Reserve Characteristics**; and
 - (iv) **Other Relevant Data**,

in respect of that **CDGU, Demand Side Unit, Interconnector transfers, Pumped Storage Plant Demand and/or Energy Storage Power Station Demand** and/or **Aggregated Generating Units** subject to any subsequent revisions to the data under SDC1 and SDC2.

SDC2.4.1.2 Additional factors which the **TSO** will also take into account are:

- (a) those **Generators** or **Demand Side Unit Operators** who have not complied with **Dispatch Instructions** or **Special Actions**;
- (b) real time variation requests; and
- (c) the need to **Dispatch CDGUs, Aggregated Generating Units, Demand Side Units, Interconnector transfers, and Pumped Storage Plant Demand and Energy Storage Power Station Demand** for **Monitoring, Testing or Investigation** purposes (and/or for other trading purposes whether at the request of a **User**, for **Commissioning or Acceptance, System Tests** or otherwise).

SDC2.4.1.3 In the event of two or more **CDGUs, Demand Side Units, Pumped Storage Plant Demand** and/or **Energy Storage Power Station Demand** and/or **Aggregated Generating Units** having the same **Price Set** and the **TSO** not being able to differentiate on the basis of the factors identified in SDC1.4.8.2, SDC1.4.8.3 and SDC1.4.8.4, then the **TSO** will select first for **Dispatch** the one which in the **TSO's** reasonable judgement is most appropriate in all the circumstances.

SDC2.4.2 **Dispatch Instructions**

SDC2.4.2.1 Introduction

Dispatch Instructions relating to the **Trading Day** will normally be issued at any time during the period beginning immediately after the issue of the first **Indicative Operations Schedule** in respect of that **Trading Day**. The **TSO** may, however, at its discretion, issue **Dispatch Instructions** in relation to a **CDGU, Demand Side Unit, Interconnector transfers, Pumped Storage Plant Demand and/or Energy Storage Power Station Demand** and/or **Aggregated Generating Units** prior to the issue of an **Indicative Operations Schedule** which includes that **CDGU, Demand Side Unit, Interconnector, Pumped Storage Plant Demand** and/or **Energy Storage Power Station Demand** and/or **Aggregated Generating Units**.

SDC2.4.2.2

Issue of Dispatch Instructions

The TSO will issue **Dispatch Instructions** direct to:

- (a) the **Generator** for the **Dispatch** of each of its **CDGUs**.
- (b) the **Generator Aggregator** for the **Dispatch** of its **Aggregated Generating Units**.
- (c) the **Energy Storage Generator** for the **Dispatch** of its **Energy Storage Power Station Demand**.
- ~~(d)~~ (d) the **Demand Side Unit Operator** and the **Pumped Storage Demand User** in respect of each of their **Demand Side Units** and **Pumped Storage Plant Demand** respectively.
- ~~(e)~~ (e) the **Interconnector Owner** for the **Dispatch** of the **Interconnector** transfers.
- ~~(f)~~ (f) The TSO may issue **Dispatch Instructions** for any **CDGU, Demand Side Unit, Interconnector** transfers, **Pumped Storage Plant Demand** and/or **Energy Storage Power Station Demand** and/or **Aggregated Generating Units** which has been declared **Available** in an **Availability Notice** even if that **CDGU, Demand Side Unit, Interconnector** transfers, **Pumped Storage Plant Demand** and/or **Energy Storage Power Station Demand** and/or **Aggregated Generating Units** was not included in an **Indicative Operations Schedule**.

SDC2.4.2.3

Scope of Dispatch Instructions

*In addition to instructions relating to the **Dispatch** of **Active Power, Dispatch Instructions** (unless otherwise specified by the TSO at the time of giving the **Dispatch Instructions**) shall be deemed to include an automatic instruction of **Operating Reserve**, the level of which is to be provided in accordance with the **Declared Operating Reserve Availability** under SDC1 and the **Ancillary Service Agreement**.*

SDC2.4.2.4

In addition to instructions relating to the **Dispatch** of **Active Power, Dispatch Instructions** in relation to **CDGUs** and, **Demand Side Units** and/or **Pumped Storage Plant Demand** and/or **Energy Storage Power Station Demand** may include:

- (a) a **Dispatch Instruction** to provide an **Ancillary Service**;
- (b) (i) **Mvars**: the individual **Reactive Power** output from **CDGUs** at the **Generator Terminals** or **Voltage** levels (at instructed **MW** level) at the **Connection Point** which will be maintained by the **CDGU**.
- (ii) The issue of **Dispatch Instructions** for **Active Power** will be as at the **Connection Point** and will be made with due regard to any resulting change in **Reactive Power** capability and may include instruction for reduction in **Active Power** generation to increase **Reactive Power** capability.
- (iii) In the event of a sudden change in **System** voltage a **Generator** must not take any action in respect of any of its **CDGUs** to override automatic **Mvar** response unless instructed otherwise by the TSO or unless immediate action is necessary to comply with stability limits. A **Generator** may take such action as is in its reasonable opinion necessary to avoid an imminent risk of injury to persons or

material damage to property (including the **CDGU**).

(iv) *Further provisions in relation to **Dispatch Instructions** regarding **Generator Reactive Power Dispatch** are set out in Appendix B to this SDC2.*

- (c) **Fuels:** **Fuels** to be used by the **Generator** in operating the **CDGU**. The **Generator** shall only be permitted to change **Fuels** with the **TSO's** prior consent.
- (d) **Special Protection Scheme:** an instruction to switch into or out of service an **Special Protection Scheme** or other **Intertripping Scheme**;
- (e) **Time to Synchronise/react:** a time to **Synchronise** or **De-Synchronise CDGUs** and, where appropriate **Demand Side Units** and/or **Energy Storage Power Stations in relation to Energy Storage Power Station Demand** and/or **Pumped Storage Plants** in relation to **Pumped Storage Plant Demand** and time to react for **Demand Side Units**;
- (f) **Synchronous Compensation:** an instruction, (where contracted, where that is necessary), for a **CDGU** to operate in **Synchronous Compensation** mode;
- (g) **Testing** etc: an instruction in relation to the carrying out of **Testing, Monitoring** or **Investigations** as required under **OC10**, or testing at the request of a **User** under **OC8.5**, or **Commissioning Testing** under the CC;

[Note: Please note that the SONI Grid Code will be referring to "OC11" and "OC11.8", whereas the EirGrid Grid Code will be referring to "OC10" and "OC8.5".]

- (h) **System Tests:** an instruction in relation to the carrying out of a **System Test** as required under **OC 8.4**;
- (i) **Maximisation:** in the case of a **CDGU** which is subject to an agreement with the **TSO** for the provision of **Maximisation** an instruction requiring it to generate at a level in excess of its **Availability** but not exceeding its **Short Term Maximisation Capability** which may only be given if, at the time of issue of the instruction, the **CDGU** is **Dispatched** to a **MW Output** equal to its **Availability** and provided that the limit on the number of hours for which such instructions may be given in any year, as set out in any arrangement relating to the relevant agreement is not thereby exceeded. Such an instruction shall be identified as a "**Maximisation Instruction**". When the **TSO** gives a **Dispatch Instruction** which is in excess of the **Availability** of the **CDGU** which is not designated a "**Maximisation Instruction**", the **Generator** must inform the **TSO** immediately that the **Dispatch Instruction** is so in excess in order that the **TSO** can so designate the **Dispatch Instruction** as a **Maximisation Instruction** or withdraw the instruction. The **Generator** shall not then be obliged to comply with the **Dispatch Instruction** unless and until the **TSO** notifies it that the instruction is designated a "**Maximisation Instruction**";
- (j) **Cycle Operating Mode:** in the case of a **CCGT Installation**, an instruction specifying the **Cycle Operating Mode** and/or an instruction to **Dispatch** a **CCGT Installation** in **Open Cycle Mode**. The **Generator** must then ensure that the **CCGT Installation** achieves the new **Dispatched Operating Mode**, without undue delay, in accordance with the **CCGT Installation's** declared **Availability** and declared **Technical Parameters**. **Dispatch Instructions** in

relation to **Cycle Operating Modes** issued by the **TSO** shall reflect the applicable **Availability Notice** and **Technical Parameters**;

- (k) **Pumped Storage**: mode changes for **Pumped Storage Plants**, where contracted, in relation to **Pumped Storage Plant Demand**;
- (l) **Energy Storage Power Station**: mode changes for **ESPS**, where contracted, in relation to **Energy Storage Power Station Demand**;
- ~~(m)~~ (m) **Under Test Flags**: **Dispatch Instructions** will, where appropriate, contain a flag to indicate that a unit is under **Within Day Test** and the part of the **Dispatch Instruction** subject to the flag will not be deemed to be a **Dispatch Instruction** for settlement purposes;
- ~~(n)~~ (n) **Gas supply emergency**: instructions relating to gas supply emergencies, where the ordinary **Dispatch** process may not be followed;

SDC2.4.2.5

Form of Instruction

- (a) Instructions may normally be given via **Electronic Interface** but can be given by telephone, by facsimile transmission. In the case of a **Special Protection Scheme**, a **Low Frequency Relay** or any other automatic **Primary Frequency Control** scheme (excluding governor response) initiated response from a **CDGU**, **Demand Side Unit**, and/or **Pumped Storage Plant** in relation to **Pumped Storage Plant Demand** and/or **Energy Storage Power Station** in relation to **Energy Storage Power Station Demand**, the instruction will be given for the effective time which is consistent with the time at which the **Low Frequency Relay** operation occurred. This **Dispatch Instruction** will be issued retrospectively.
- (b) The reduction by a **Generator** of the **MW Output** of one of its **CDGUs** under **OC4.3** shall be deemed to have followed a **Dispatch Instruction** issued by the **TSO**.
- (c)
 - (i) In the event of a temporary loss of the **NI Control Centre/National Control Centre** as described under **OC9**, each **Generator** shall, subject to the provisions of SDC2.4.2.5(c)(ii), continue to operate its **CDGUs** in accordance with the last **Dispatch Instructions** to have been issued by the **TSO** but shall use all reasonable endeavours to maintain **System Frequency** at the indicated **Target Frequency** plus or minus 0.05Hz by monitoring **Frequency** and increasing/decreasing the **MW Output** of its **CDGUs** as necessary until such time as new **Dispatch Instructions** are received from the **TSO**.
 - (ii) When operating its **CDGUs** in the circumstances described under SDC2.4.2.5(c)(i), a **Generator** shall never be required to **Dispatch** these units in a manner in which the **TSO** would not be entitled to require such units to be **Dispatched** by means of a **Dispatch Instruction** issued in accordance with this SDC2.
- (d) The **De-Synchronisation** of a **CDGU** following the operation of a **Special Protection Scheme** selected by the **TSO** shall be deemed to have happened as a result of a **Dispatch Instruction** issued by the **TSO**.

SDC2.4.2.6

Target Frequency

- (a) **Dispatch Instructions** to **Generators** will generally indicate the target **MW** (at **Target Frequency**) to be provided at the **Connection Point** to be achieved in accordance with the respective **CDGU's Technical Parameters** and/or parameters as provided in the **Additional Grid Code Characteristics Notices** provided under SDC1 or this SDC2, or such rate within those parameters as is specified by the **TSO** in the **Dispatch Instructions**.
- (b) **Dispatch Instructions** deemed to be given upon the operation of an agreed **Low Frequency Relay** will be deemed to indicate the target **MW** (at **Target Frequency**), which may either be at maximum **MW Output** or at some lower **MW Output** (as previously specified by the **TSO**), to be provided at the **Connection Point** which reflects and is in accordance with the **CDGU's Technical Parameters** and/or parameters as provided in the **Additional Grid Code Characteristics Notice** data given under (or as revised in accordance with) SDC1 or this SDC2.

SDC2.4.2.7

To aid clarity, the form of and terms to be used by the **TSO** in issuing instructions together with their meanings are set out in the Appendices to this SDC2.

SDC2.4.2.8

- (a) Subject only to SDC2.4.2.9 and as provided below in this SDC2.4.2.8, **Dispatch Instructions** will not be inconsistent with the **Availability** and/or **Technical Parameters** and/or **Additional Grid Code Characteristics Notice** data and **Other Relevant Data** notified to the **TSO** under SDC1 (and any revisions under SDC1 or this SDC2 to that data).
- (b) A new **Dispatch Instruction** may be subsequently given (including an instruction for a **Cancelled Start**) at any time.
- (c) **Dispatch Instructions** may however be inconsistent with the **Availability** and/or **Technical Parameters** and/or **Additional Grid Code Characteristics Notice** data and/or **Other Relevant Data** so notified to the **TSO** for the purposes of carrying out a test at the request of the relevant **Generator** under OC8.5 or a **System Test** at the request of the relevant **Generator** under OC8.6, to the extent that such **Dispatch Instructions** are consistent with the procedure agreed (or otherwise determined) for conducting the test or **System Test** (as the case may be).
- (d) For the avoidance of doubt, any **Dispatch Instructions** issued by the **TSO** for the purposes of carrying out a test at the request of the relevant **Generator** under OC8.5 or a **System Test** at the request of the relevant **Generator** under OC8.6 shall not be deemed to be **Dispatch Instructions** given pursuant to SDC2.4.2.9.

SDC2.4.2.9

- (a) To preserve **System** integrity under emergency circumstances where, for example, **Licence Standards** cannot be met the **TSO** may, however, issue **Dispatch Instructions** to change **CDGU**, **Aggregated Generating Units**, **Demand Side Unit**, **Interconnector** transfers and/or **Pumped Storage Plant Demand MW Output** and/or **Energy Storage Power Station Demand MW Output** or **Demand Side Unit MW Response** even when this is outside parameters so registered or so amended. This may, for example, be an instruction to trip or partially load a **CDGU**. The instruction will be stated by the **TSO** to be one in relation to emergency circumstances under SDC2.4.2.9.
- (b) A **User** may refuse to comply or continue to comply with instructions referred to in this SDC2.4.2.9 but only in order to avoid, in the **Generator's**

reasonable opinion, an imminent risk of injury to persons or material damage to property (including in the case of a **Generator**, the **CDGU**).

SDC2.4.2.10 Communication with Users

- (a) **Dispatch Instructions** whether given via **Electronic Interface**, by telephone, by facsimile transmission must formally acknowledged immediately by the **User** at the **Control Facility** by **Electronic Interface** or, with the **TSO's** prior consent, by telephone, by return facsimile transmission, in the manner agreed between the **User** and the **TSO** or a reason must be given as soon as possible for non-acceptance, which may (subject to SDC2.4.2.9) only be to avoid, in the **User's** reasonable opinion, an imminent risk of injury to persons or material damage to property (including the **CDGU**) or because they are not in accordance with the applicable **Availability Notice**, or **Technical Parameters**, or **Additional Grid Code Characteristics Notices** or do not reflect **Other Relevant Data** submitted by the **User** pursuant to SDC1.
- (b) In the event that in carrying out the **Dispatch Instructions**, an unforeseen problem arises, giving rise, in the **User's** reasonable opinion, to an imminent risk of injury to persons or material damage to property (including the **CDGU**) the **TSO** must be notified as soon as possible by telephone.

SDC2.4.2.11 Action Required from Users

- (a) Each **User** will comply in accordance with SDC2.4.2.12 with all **Dispatch Instructions** given by the **TSO** unless the **User** has given notice to the **TSO** under the provisions of SDC2.4.2.10 regarding non-acceptance of **Dispatch Instructions**.
- (b) When complying with **Dispatch Instructions** for a **CCGT Installation** a **Generator** will operate its **CCGT Units** in accordance with the applicable **CCGT Installation Matrix**.
- (c) Where the **TSO** issues a **Synchronising** time to a **Generator** for a specific **CDGU** (other than an **Open Cycle Gas Turbine**) and the **Generator** identifies that such **CDGU** will not be **Synchronised** within **+/- 10 minutes** of the instructed time, the **Generator** must immediately (at the time the discrepancy is identified) inform the **TSO** of the situation and estimate the new **Synchronising** time.
- (d) If the **Synchronising** time of the **CDGU** (other than an **Open Cycle Gas Turbine**) is different from the instructed time by more than 15 minutes but less than 1 hour, this will constitute a **Short Notice Re-declaration** by the **CDGU** for that **Generator**.
- (e) If the **Synchronising** time of the **CDGU** (other than an **Open Cycle Gas Turbine**) is different from the instructed time by more than 1 hour, this will constitute a **Re-declaration** for the **CDGU** by the **Generator**.

SDC2.4.2.12 Implementation of Instructions by Users

When a **User** has received a **Dispatch Instruction** given by the **TSO**, it will react by responding to that **Dispatch Instruction** given by the **TSO** without undue delay, and, in any event, within one minute in accordance with the instruction *or in the case of **Dispatch Instructions for Mvars** within two minutes of the instruction*, including those **Dispatch Instructions** issued pursuant to SDC2.4.2.9. Instructions indicating a target **MW Output** at the **Target Frequency** will be complied with by **Users** notwithstanding any tolerance bands set out in any **Testing** requirement or elsewhere in the **Grid Code**.

- SDC2.4.2.13 (a) Subject to the exception set out below in this SDC2.4.2.13, **Generators** will only **Synchronise** or **de-Synchronise CDGUs** to the **Dispatch Instructions** of the **TSO** or unless it occurs automatically as a result of **Special Protection Schemes** or **Low Frequency Relay** operations. Subject to the exception set out below in this SDC2.4.2.13, **Demand Side Unit Operators** will only reduce or increase their **Demand Side Unit MW Response** to the **Dispatch Instructions** of the **TSO** or unless it occurs automatically as a result of **Special Protection Schemes** or **Low Frequency Relay** operations.
- (b) **De-Synchronisation** may otherwise only take place without the **TSO's** prior agreement if it is to avoid, in the **Generator's** reasonable opinion, an imminent risk of injury to persons or material damage to property (including the **CDGU**). **Demand Side Units**, who cannot maintain the provision of any **Demand Side Unit MW Response**, may otherwise only take place without the **TSO's** prior agreement if it is to avoid, in the **Demand Side Unit Operator's** reasonable opinion, an imminent risk of injury to persons or material damage to property (including the **Demand Side Unit**).
- (c) If one of these exceptions occur, then the **TSO** must be informed that it has taken place as soon as possible.
- SDC2.4.2.14 The **TSO** may suspend the issue of **Dispatch Instructions** to **User's Plant** in accordance with the **Merit Order** (having taken account of and applied the factors referred to in SDC1.4.8.3) to the extent that the conditions in SDC1.4.8.6 or SDC2.4.2.4(m) arise. When necessary the **TSO** will issue **Dispatch Instructions** for a **Black Start**.
- SDC2.4.2.15 **User Plant Changes**
- Each **User** at its **Control Facility** will, without delay, notify the **TSO** by **Electronic Interface**, telephone or by facsimile transmission of any change or loss (temporary or otherwise) to the operational capability of its **Plant** including any changes to the **Technical Parameters** and/or **Additional Grid Code Characteristics Notice** data of each of the **User's Plant** (in the case of **Technical Parameters**, by the submission of a **Technical Parameters Revision Notice**) indicating (where possible) the magnitude and the duration of the change. In the case of **CDGUs** already **Synchronised** to the **System**, each **Generator**, in respect of its **Generating Units**, must also state whether or not the loss was instantaneous.
- SDC2.4.2.16 Each **Generator**, in respect of its **Generating Units**, will operate its **Synchronised CDGUs** with **AVRs** and **Var** limiters in service at all times (where required pursuant to *CC7.3 and SDC2.B.7*) unless released from this obligation in respect of a particular **CDGU** by the **TSO**.
- SDC2.4.2.17 Each **Generator**, in respect of its **Generating Units**, shall request the **TSO's** agreement for one of its **CDGUs** at that **Generating Plant** to be operated without the **AVR** or **Var** limiter in service. The agreement of the **TSO** will be dependent on the risk that would be imposed on the **System**. However, a **Generator** may, in any event, take such action in relation to that **CDGU** as is reasonably necessary to avoid, in the **Generator's** reasonable opinion, an imminent risk of injury to persons or material damage to property (including the **CDGU**).
- SDC2.4.2.18 **Minimum Demand Regulation ("MDR")**
- Synchronised CDGUs** must at all times be capable of reducing **MW Output** sufficient to allow a sufficient **Regulating Margin** for adequate **Frequency Control**. The **TSO** will monitor the **MW Output** data of the **Indicative Operations**

Schedule against the forecast **Demand** to see whether the level of **MDR** for any period is insufficient, and may take any shortfall into account in **Dispatch**.

SDC2.4.3

Special Actions

The **TSO** may also issue **Dispatch Instructions** for **Special Actions** (either pre- or post-fault) to a **User** in respect of any of its **Plant** in the event that the **TSO** in its reasonable opinion believes that such instructions are necessary in order to ensure that the **Licence Standards** are met. **Special Actions** will generally involve a **Load** change, a **Load** reduction change or a change in required **Notice to Synchronise** (or, in the case of a **Demand Side Unit** or **Pumped Storage Plant Demand** or **Energy Storage Power Station Demand**, a change in the relevant effective time) in a specific timescale on individual or groups of **CDGUs**. They may also include selection of **Special Protection Scheme** for stability or thermal reasons. Instructions for **Special Actions** will always be within **Technical Parameters**.

SDC2 - APPENDIX A

Dispatch Instructions for CDGUs and Demand Side Units

- SDC2.A.1 General
- This Appendix A to SDC2 provides further information on the form of a **Dispatch Instruction** as well as an example of a **Dispatch Instruction** for **CDGUs** and **Demand Side Units**.
- SDC2.A.2 Form of Dispatch Instruction
- SDC2.A.2.1 All **Loading/De-Loading Rates** will be assumed to be in accordance with **Technical Parameters** and **Additional Grid Code Characteristics Notice** data. Each **Dispatch Instruction** will, wherever possible, be kept simple, drawing as necessary from the following forms and SDC2.4.2.
- SDC2.A.2.2 The **Dispatch Instruction** given by **Electronic Interface**, telephone, or facsimile transmission will normally follow the form:
- (a) where appropriate, the specific **CDGU** or **User's Plant** to which the instruction applies;
 - (b) the **MW Output** (or **Demand Side Unit MW Response**) to which it is instructed;
 - (c) if the start time is different from the time the instruction is issued, the start time will be included;
 - (d) where specific **Loading/De-Loading Rates** are concerned, a specific target time;
 - (e) the issue time of the instruction;
 - (f) the fuel;
 - (g) in the case of **CDGUs**, if the instruction is designated as a "**Maximisation Instruction**", this will be stated; and
 - (h) in the case of a **CCGT Installation**, the **Operating Mode** to which it is instructed.
- SDC2.A.3 Dispatching a Synchronised CDGU to increase or decrease MW Output
- SDC2.A.3.1 If the time of the **Dispatch Instruction** is 1400 hours, the Unit is Unit 1 and the **MW Output** to be achieved is 205 **MW**, the relevant part of the instruction would be, for example:
"Time 1400 hours. Unit 1 to 205 **MW**"
- SDC2.A.3.2 If the start time is 1415 hours, it would be, for example:
"Time 1400 hours. Unit 1 to 205 **MW**, start at 1415 hours"
- SDC2.A.3.3 **Loading** and **De-Loading Rates** are assumed to be in accordance with **Technical Parameters** and **Additional Grid Code Characteristics Notice** data unless otherwise stated. If different **Loading** or **De-Loading Rates** are required, the time to be achieved will be stated, for example:
"Time 1400 hours. Unit 1 to 205 **MW** by 1420 hours"
- SDC2.A.4 Dispatching a CDGU to Synchronise/de-Synchronise

SDC2.A.4.1 **CDGU Synchronising**

SDC2.A.4.1.1 In this instance, for **CDGUs**, the **Dispatch Instruction** issue time will always have due regard for the **Synchronising** time declared to the **TSO** by the **Generator** as a **Technical Parameters** or as part of **Additional Grid Code Characteristics Notice** data.

The instruction will follow the form, for example:

"Time 1300 hours. Unit 1, **Synchronise** at 1600 hours"

In relation to an instruction to **Synchronise**, the start time referred to in SDC2.A.2.2 will be deemed to be the time at which **Synchronisation** is to take place.

SDC2.A.4.1.2 Unless a **Loading** programme is also given at the same time it will be assumed that the **CDGU(s)** are to be brought to **Minimum Generation** and on the **Generator** reporting that the unit has **Synchronised** a further **Dispatch Instruction** will be issued.

SDC2.A.4.1.3 When a **Dispatch Instruction** for a **CDGU** to **Synchronise** is cancelled (ie. a **Cancelled Start**) before the unit is **Synchronised**, the instruction will follow the form, for example:

"Time 1400 hours. Unit 1, cancel **Synchronising** instruction"

SDC2.A.4.1.4 If a **CDGU** fails to **Synchronise** more than 5 minutes after the time specified in a **Notice to Synchronise**, the **TSO** may issue a **Failure to Follow Notice to Synchronise Instruction**. If a **Generator** requests to **Synchronise** a **CDGU** more than 15 minutes before the time set out in the **Notice to Synchronise**, the **TSO** may agree to the **CDGU** being **Synchronised** at that time or request that the **CDGU** be **Synchronised** at the original **Notice to Synchronise** time. If the **TSO** accepts the request to **Synchronise** more than 15 minutes before the original **Notice to Synchronise** time, the **TSO** will not amend the original **Notice to Synchronise** time but the **Generator** shall be entitled to **Synchronise the CDGU**, and the **CDGU** shall be deemed to have met the original **Notice to Synchronise** time.

SDC2.A.4.1.5 When in respect of a **CDGU** a **Generator** receives a **Failure to Follow Notice to Synchronise Instruction** the original **Notice to Synchronise** is deemed never to have been issued and the **CDGU** is not entitled to **Synchronise**. The **TSO** will then decide whether or not to instruct again the **Generator to Synchronise the CDGU**, and will notify the **Generator** in relation to that **CDGU** accordingly.

SDC2.A.4.1.6 When a **CDGU** trips before reaching **Minimum Generation** a **Failure to Reach Minimum Generation Instruction** will be issued. The **Failure to Reach Minimum Generation Instruction** will negate the **Notice to Synchronise** received by the **CDGU**. The **TSO** will then decide whether or not to instruct the **CDGU** to **Synchronise** again, and will notify the **Generator** in relation to that **CDGU** accordingly.

SDC2.A.4.2 **CDGUs De-Synchronising**

SDC2.A.4.2.1 The **Dispatch Instruction** will normally follow the form, for example:

"Time 1300 hours. Unit 1, **Shutdown**"

If the instruction start time is for 1400 hours the form will be, for example:

"Time 1300 hours. Unit 1, **Shutdown**, start at 1400 hours"

Both the above assume **De-Loading Rate** at declared **Technical Parameters**. Otherwise the message will conclude with, for example:

"... and **De-Synchronise** at 1500 hours"

SDC2.A.5 **Frequency Control**

SDC2.A.5.1 All the above **Dispatch Instructions** will be deemed to be at the instructed **Target Frequency**, i.e. where a **CDGU** is in the **Frequency Sensitive Mode** instructions refer to target **MW Output** at **Target Frequency**. **Target Frequency** changes will always be given to the **Generator** by telephone or **Electronic Interface** and will normally only be 49.95, 50.00, 50.05Hz.

*The adjustment of **MW Output** of a **CDGU** for **System Frequency** other than an average of 50 Hz, shall be made in accordance with the current **Declared** value of **Governor Droop** for the **CDGU**.*

SDC2.A.5.2 **CDGUs** required to be **Frequency** insensitive will be specifically instructed as such. The **Dispatch Instruction** will be of the form for example:

"Time 2100 hours. Unit 1, to **Frequency** insensitive mode"

SDC2.A.5.3 **Frequency Control** instructions may be issued in conjunction with, or separate from, a **Dispatch Instruction** relating to **MW Output**.

SDC2.A.6 **Emergency Load Drop**

The **Dispatch Instruction** will be in a pre-arranged format and normally follow the form, for example:

"Time 2000 hours. Emergency **Load** drop of "X"**MW** in "Y" minutes"

SDC2.A.7 **Voltage Control Instruction**

[Note: Voltage is used as a defined term in the EirGrid code but not in the SONI Code.]

In order that adequate **System Voltage** profiles are maintained under normal and fault conditions a range of **Voltage Control** instructions will be utilised from time to time, for example:

- (a) Operate to target **Voltage** of 117 kV;
- (b) Maximum production or absorption of **Reactive Power** (at current instructed **MW Output**)
- (c) Increase reactive output by 10 **Mvar** (at current instructed **MW Output**);
- (d) *Change **Reactive Power** to 100 **Mvar** production or absorption;*
- (e) *Increase **CDGU Generator** step-up transformer tap position by [one] tap or go to tap position [x];*
- (f) *For a **Simultaneous Tap Change**, change **CDGU Generator** step-up transformer tap position by one [two] taps to raise or lower (as relevant) **System Voltage**, to be executed at time of telegraph (or other) **Dispatch Instruction**.*

(g) Achieve a target **Voltage** of 210 kV and then allow to vary with **System** conditions; and

(h) Maintain a target **Voltage** of 210 kV until otherwise instructed. Tap change as necessary.”

In relation to **Mvar Dispatch** matters, **Mvar** production is an export onto the **System** and is referred to as “lagging **Mvar**”, and **Mvar** absorption is an import from the **System** and is referred to as “leading **Mvar**”.

It should be noted that the excitation control system constant **Reactive Power** level control mode or constant **Power Factor** output control mode will always be disabled, unless agreed otherwise with the **TSO**.

SDC2.A.8 Instruction to change fuel

When the **TSO** wishes to instruct a **Generator** to change the fuel being burned in the operation of one of its **CDGUs** from one **Dispatched Fuel** (or fuel) to another (for example from 1% sulphur oil to 3% sulphur oil), the **Dispatch Instruction** will follow the form, for example:

"Time 1500 hours. Unit 2 change to 3% fuel at 1700 hours".

SDC2.A.9 Instruction to change fuel for a dual firing CDGU

When the **TSO** wishes to instruct a **Generator** to change the fuel being burned in the operation of one of its **CDGUs** which is capable of firing on two different fuels (for example, coal or oil), from one **Designated Fuel** (or fuel) to another (for example, from coal to oil), the instruction will follow the form, for example:

"Time 1500 hours. Unit 1 generate using oil at 1800 hours".

SDC2.A.10 Maximisation Instruction to CDGUs

When the **TSO** wishes to instruct a **Generator** to operate a **CDGU** at a level in excess of its **Availability** in accordance with SDC2.4.2.4(i), the instruction will follow the form, for example:

"**Maximisation Instruction.** Time 1800 hours. Unit GT2 to 58 **MW.**"

SDC2.A.11 Emergency Instruction

*If a **Dispatch Instruction** is an **Emergency Instruction** the **Dispatch Instruction** will be prefixed with the words. This is an **Emergency Instruction**. It may be in a pre-arranged format and normally follow the form, for example:*

*This is an **Emergency Instruction**. Reduce **MW Output** to "X"**MW** in "Y" minutes, **Dispatch Instruction** timed at 2000 hours.*

SDC2.A.12 Dispatching a Demand Side Unit to a Demand Side Unit MW Response

SDC2.A.12.1 For **Demand Side Units**, the **Dispatch Instruction** issue time will always have due regard for the **Demand Side Unit Notice Time** declared to the **TSO** by the **Demand Side Unit Operator** as a **Technical Parameter** or as part of **Additional Grid Code Characteristics Notice** data.

SDC2.A.12.2 If the time of the **Dispatch Instruction** is 1400 hours, the **Demand Side Unit** is XX1, the **Demand Side Unit Notice Time** is 10 minutes and the **Demand Side Unit MW Response** to be achieved is 20 **MW**, the relevant part of the instruction would be for example:

"Time 1400 hours. Unit XX1 to 20 **MW**, start at 1410 hours"

SDC2 - APPENDIX B

[Note: This Appendix applies to the EirGrid Grid Code only.]

Dispatch Instructions for Generator Reactive Power

- SDC2.B.1** The **Mvar Output** of any **CDGU** in respect of which a **Dispatch Instruction** is given under SDC2.4.2.4(b) shall, in accordance with its declared **Technical Parameters**, be adjusted to the new target **Mvar** level so **Instructed**, within, a tolerance of +/- 2% of the target or +/- 2 **Mvar**, whichever is greater. The **Reactive Power** output of a **CDGU** shall not be adjusted (other than under **AVR** action) except in response to a **Dispatch Instruction** from the **TSO**.
- SDC2.B.2** **Generators** having achieved the new target **Mvar Output**, should not attempt to sustain this level of **Mvar Output** as the **System Voltage** varies but should, rather, allow the **Reactive Power** output to vary under **AVR** control in accordance with the then applicable **Declarations of Ancillary Service** capabilities and **Technical Parameters**.
- SDC2.B.3** While a **Reactive Power Dispatch Instruction** shall normally specify a new **Mvar** target for a **CDGU**, the **TSO** may also from time to time instruct **Generators** to perform one or more tap changes on the generator step-up transformer of a **CDGU**. The **Dispatch Instructions** for tap changes may be a **Simultaneous Tap Change Instruction** whereby the tap change shall be effected by the **Generator** in response to a **Dispatch Instruction** from the **TSO** issued simultaneously to relevant **Power Stations**. The **Dispatch Instruction**, which is normally preceded by advance warning, shall be effected within 1 minute of receipt from the **TSO** of the **Dispatch Instruction**.
- SDC2.B.4** **Dispatch Instructions** in relation to **Reactive Power** may include target voltage levels to be achieved by the **CDGU** on the **Transmission System** at **Grid Connection Point** (or on the **User System** at the **User System Entry Point** in the case of an **Embedded Generator**, namely on the higher voltage side of the **Generator** step-up transformer). Where a **CDGU** is **Instructed** to a specified target voltage, the **Generator** shall achieve that target within a tolerance of 1 kV by tap changing on the **Generator** step-up transformer unless otherwise agreed with the **TSO**. Under normal operating conditions, once this target voltage level has been achieved, the **Generator** shall not tap change again without prior consultation with and agreement of the **TSO**.
- SDC2.B.5** Under certain conditions such as low **System Voltage**, a **Dispatch Instruction** to maximum **Mvar** production at **Instructed MW Output** may be given and the **Generator** shall take appropriate action to maximise **Mvar** production unless constrained by plant operational limits or safety grounds relating to personnel or plant.
- SDC2.B.6** Under certain conditions such as high **System Voltage**, a **Dispatch Instruction** to maximum **Mvar** absorption at **Instructed MW Output** may be given and the **Generator** shall take appropriate action to maximise **Mvar** absorption unless constrained by plant operational limits or safety grounds relating to personnel or plant.
- SDC2.B.7** The excitation system, unless otherwise agreed with the **TSO**, shall be operated only in its constant terminal voltage mode of operation with var limiters in service, with any constant **Reactive Power** output control mode or constant **Power Factor** output control mode always disabled, unless agreed otherwise with the **TSO**.
- SDC2.B.8** A **Dispatch Instruction** relating to **Reactive Power** will be implemented without delay and, notwithstanding the provisions of SDC2.4.2.12 and subject as provided in this Appendix B will be achieved not later than 2 minutes after the **Dispatch Instruction** time, or such longer period as the **TSO** may **Instruct**.
- SDC2.B.9** Where **Dispatch Instructions** relating to **Active Power** and **Reactive Power** are given together, and to achieve the **Reactive Power** output would cause the **CDGU** to

operate outside **Technical Parameters** as a result of the **Active Power Dispatch Instruction** being met at the same time, then the adjustment of the **Reactive Power** output may be delayed until the operating limits no longer prevent the change. In any case the **Active and Reactive Power Dispatch Instruction** shall be followed without undue delay.

- SDC2.B.10 In circumstances where the **TSO** issues new **Dispatch Instructions** in relation to more than one **CDGU** at the same **Power Station** at the same time tapping will be carried out by the **Generator** one tap at a time either alternately between (or in sequential order, if more than two), or at the same time on, each **CDGU**, as the case may be.
- SDC2.B.11 Where the **Dispatch Instructions** require more than two taps per **CDGU** and that means that the **Dispatch Instructions** cannot be achieved within 2 minutes of the time of the **Dispatch Instructions** (or such longer period at the **TSO** may have Instructed), the **Dispatch Instructions** shall each be achieved with the minimum of delay after the expiry of that period;
- SDC2.B.12 On receiving a new **MW Dispatch Instruction**, no tap changing shall be carried out to change the **Mvar Output** unless there is a new **Mvar Dispatch Instruction**.
- SDC2.B.13 Where a **Dispatch Instructions to Synchronise** is given, or where a **CDGU** is **Synchronised** and a **MW Dispatch Instruction** is given, a **Mvar Dispatch Instruction** consistent with the **CDGU's** relevant parameters may be given. In the absence of a **Mvar Dispatch Instruction** with an instruction to **Synchronise**, the **Mvar Output** should be 0 **Mvar**.
- SDC2.B.14 Where a **Dispatch Instructions to De-Synchronise** is given, a **Mvar Dispatch Instruction**, compatible with shutdown, may be given prior to **De-Synchronisation** being achieved. In the absence of a separate **Mvar Dispatch Instruction**, it is implicit in the **Dispatch Instructions to De-Synchronise** that **Mvar** output should at the point of synchronism be 0 **Mvar** at **De-Synchronisation**.
- SDC2.B.15 A **Dispatch Instruction** relating to **Reactive Power** may be given in respect of **CCGT Units** within a **CCGT Installation** where running arrangements and/or **System** conditions require, in both cases where connection arrangements permit.
- SDC2.B.16 On receipt of a **Dispatch Instruction** relating to **Reactive Power**, the **Generator** may take such action as is necessary to maintain the integrity of the **CDGU** (including, without limitation, requesting a revised **Dispatch Instruction**), and shall contact the **TSO** without delay.
- SDC2.B.17 Under **System** fault conditions it is possible for **AVR** action to drive **Reactive Power** output for a **CDGU** outside of its **Declared Operating Characteristic** limits. The **Generator** shall immediately inform the **TSO** of the situation. However if the **Generator** reasonably believes that the situation may be dangerous to personnel or **Plant**, then limited action may be taken to improve the situation.

~~WFPS1~~ PPM1 CONTROLLABLE ~~WIND FARM POWER STATION~~ PPM GRID CODE PROVISIONS

~~WFPS~~ PPM 1 CONTROLLABLE ~~WIND FARM POWER STATION~~ PPM GRID CODE PROVISIONS

~~WFPS~~ PPM 1.1 INTRODUCTION

All **Generators** connecting to the **Transmission System** are required to comply with the **Grid Code**. The **Grid Code** was originally developed with synchronous generators in mind. Since ~~Wind Turbine Generators (WTG)~~ **Generation Units** do not have the same characteristics as synchronous generators, it was considered appropriate to develop a new set of **Grid Code** provisions specifically for ~~Controllable WFPSs~~ **Controllable PPMs**. This section of the **Grid Code** gives the specific requirements for ~~Controllable WFPSs~~ **Controllable PPMs** and ~~WFPS Extensions~~ **PPM Extensions** to pre-existing ~~Controllable WFPSs~~ **Controllable PPMs** where an extension to a ~~WFPS~~ **PPM** shall be classified as one of the following two types:

(a) Transmission Connected Type A

A ~~WFPS Extension~~ **PPM Extension** which is not separately controllable.

(b) Transmission Connected Type B

A ~~WFPS Extension~~ **PPM Extension** which is separately controllable will be considered as a unique ~~WFPS~~ **PPM** with the exception of its requirements to ~~WFPS~~ **PPM 1.6 Transmission System Voltage Requirements** which will be tested in aggregate with the existing ~~Controllable WFPS~~ **Controllable PPM**.

Transmission Connected Type A ~~WFPS Extensions~~ **PPM Extensions** and Transmission Connected Type B ~~WFPS Extensions~~ **PPM Extensions** will be subject to full **Grid Code** Compliance testing at the discretion of the **TSO**. Where a ~~Controllable WFPS~~ **Controllable PPM** has been granted derogations or exemptions from the **Grid Code** any ~~WFPS Extension~~ **PPM Extension** to that ~~Controllable WFPS~~ **Controllable PPM** will be a Transmission Connected Type B ~~WFPS Extension~~ **PPM Extension**.

~~WFPS~~ PPM 1.2 OBJECTIVE

The primary objective of ~~WFPS1~~ **PPM1** is to establish the technical rules which ~~Controllable WFPSs~~ **Controllable PPMs** and ~~WFPS Extensions~~ **PPM Extensions** must comply with in relation to their connection to and operation on the **Transmission System**.

~~WFPS~~ PPM 1.3 SCOPE

~~WFPS~~ PPM 1.3.1 ~~WFPS1~~ **PPM1** applies to the following **Users**:

- (a) The **TSO**;
- (b) **Grid Connected** ~~Controllable WFPSs~~ **Controllable PPMs**; and

FORM GC1

- (c) **Grid Connected ~~Controllable WFPS Extensions~~ PPM Extensions;** and
- (d) **Grid Connected Energy Storage Power Station Demand**

~~WFPS PPM~~ 1.3.2 In addition to ~~WFPS1 PPM1~~, ~~Controllable WFPSs~~ **Controllable PPMs** and **Energy Storage Power Station Demand** are required to comply with the following sections of the **Grid Code**:

- GC - General Conditions
- PC - Planning Code
- PCA – Planning Code Appendix
- CC- Connection Conditions excluding:
 - CC 7.2.5.1
 - CC 7.2.5.2
 - CC7.3.1.1(a) to (h) and (j) to (u)
 - CC7.3.1.2
 - CC7.3.5
 - CC7.3.6
 - CC7.3.7
 - CC7.3.8
 - CC.12.2
 - CC.12.3
- OC1
- OC2
- OC4 excluding:
 - OC4.3.4
 - OC4.4.5.3
 - OC4.4.5.4
 - OC4.4.5.5
- OC6
- OC7 excluding
 - OC7.2.4.2
- OC8
- OC9
- OC10 excluding
 - OC10.5.7
 - OC10.7.1
 - OC10.7.2
 - OC10.7.3
 - OC10.7.4
 - OC10.7.6
- OC11
- SDC1

Dispatchable ~~WFPSs~~ PPMs and Energy Storage Power Station Demand are also required to comply with SDC2.

In the Grid Code, where applicable, for the purposes of ~~Controllable WFPSs~~ Controllable PPMs references to Generation Unit or Generator should be interpreted to mean ~~Controllable WFPS~~ Controllable PPM.

For the avoidance of doubt, within PPM1, references to Controllable PPM and PPM also include Energy Storage Power Station Demand.

WFPS PPM 1.4 FAULT RIDE THROUGH REQUIREMENTS

WFPS PPM 1.4.1 A ~~Controllable WFPS~~ Controllable PPM shall remain connected to the Transmission System for Transmission System Voltage Dips on any or all phases, and shall remain Stable, where the Transmission System Phase Voltage measured at the HV terminals of the Grid Connected Transformer remains above the heavy black line in Figure WFPS1.1.

Fault Ride Through Capability of ~~Wind Farm Power Stations~~ PPMs

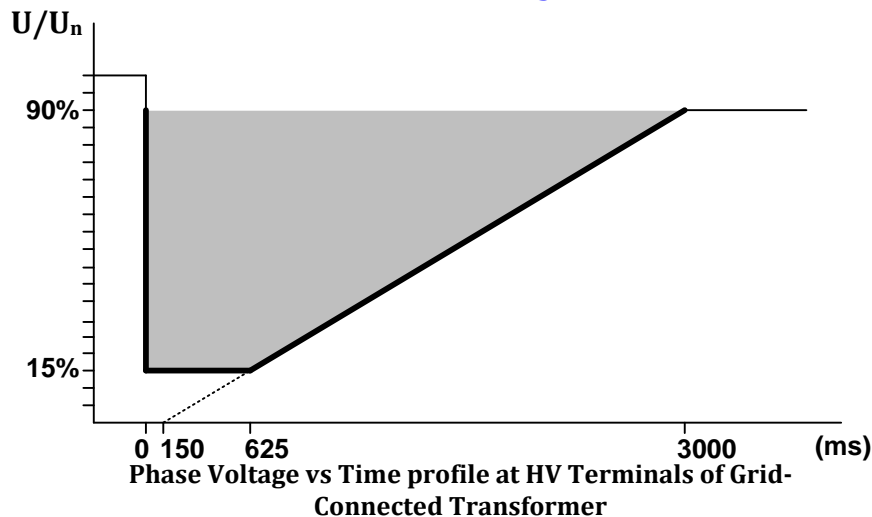

Figure WFPS1.1 - Fault Ride-Through Capability of ~~Controllable WFPSs~~ Controllable PPMs

WFPS PPM 1.4.2 In addition to remaining connected to the Transmission System, the ~~Controllable WFPS~~ Controllable PPM shall have the technical capability to provide the following functions:

- a) During Transmission System Voltage Dips, the ~~Controllable WFPS~~ Controllable PPM shall provide Active Power in proportion to retained Voltage and provide reactive current to the Transmission System, as set out in WFPS PPM1.4.2(c). The provision of reactive current shall continue until the Transmission System Voltage recovers to within the normal operational range

of the **Transmission System** as specified in CC8.3.1, or for at least 500 ms, whichever is the sooner. The ~~Controllable-WFPS~~ **Controllable PPM** may use all or any available reactive sources, including installed statcoms or SVCs, when providing reactive support during **Transmission System Fault Disturbances** which result in **Voltage Dips**.

- b) The ~~Controllable-WFPS~~ **Controllable PPM** shall provide at least 90 % of its maximum **Available Active Power** or **Active Power Set-point**, whichever is lesser, as quickly as the technology allows and in any event within 500 ms of the **Transmission System Voltage** recovering to 90% of nominal **Voltage**, for **Fault Disturbances** cleared within 140 ms. For longer duration **Fault Disturbances**, the ~~Controllable-WFPS~~ **Controllable PPM** shall provide at least 90% of its maximum **Available Active Power** or **Active Power Set-point**, whichever is lesser, within 1 second of the **Transmission System Voltage** recovering to 90% of the nominal **Voltage**.
- c) During and after faults, priority shall always be given to the **Active Power** response as defined in ~~WFPS~~ PPM1.4.2(a) and ~~WFPS~~ PPM1.4.2(b). The reactive current response of the ~~Controllable-WFPS~~ **Controllable PPM** shall attempt to control the **Voltage** back towards the nominal **Voltage**, and should be at least proportional to the **Voltage Dip**. The reactive current response shall be supplied within the rating of the ~~Controllable-WFPS~~ **Controllable PPM**, with a **Rise Time** no greater than 100ms and a **Settling Time** no greater than 300ms. For the avoidance of doubt, the ~~Controllable-WFPS~~ **Controllable PPM** may provide this reactive response directly from individual ~~WTGs~~ **Generation Units**, or other additional dynamic reactive devices on the site, or a combination of both.
- d) The ~~Controllable-WFPS~~ **Controllable PPM** shall be capable of providing its transient reactive response irrespective of the reactive control mode in which it was operating at the time of the **Transmission System Voltage Dip**. The ~~Controllable-WFPS~~ **Controllable PPM** shall revert to its pre-fault reactive control mode and setpoint within 500ms of the **Transmission System Voltage** recovering to its normal operating range as specified in CC.8.3.1.
- e) The **TSO** may seek to reduce the magnitude of the dynamic reactive response of the ~~Controllable-WFPS~~ **Controllable PPM** if it is found to cause over-voltages on the **Transmission System**. In such a case, the **TSO** will make a formal request to the ~~Controllable-WFPS~~ **Controllable PPM**. The ~~Controllable-WFPS~~ **Controllable PPM** and the **TSO** shall agree on the required changes, and the ~~Controllable-WFPS~~ **Controllable PPM** shall formally confirm that any requested changes have been implemented within 120 days of received the **TSO's** formal request.

WFPS PPM 1.5.1 ~~Controllable-WFPSs~~ **Controllable PPMs** shall have the capability to:

- a) operate continuously at normal rated output at **Transmission System Frequencies** in the range 49.5 Hz to 50.5 Hz;
- b) remain connected to the **Transmission System** at **Transmission System Frequencies** within the range 47.5 Hz to 52.0 Hz for a duration of 60 minutes;
- c) remain connected to the **Transmission System** at **Transmission System Frequencies** within the range 47.0 Hz to 47.5 Hz for a duration of 20 seconds required each time the **Transmission System Frequency** is below 47.5 Hz;
- d) remain connected to the **Transmission System** during rate of change of **Transmission System Frequency** of values up to and including 0.5 Hz per second.

No additional **WTG Generation Unit** shall be started while the **Transmission System Frequency** is above 50.2 Hz.

In the case of **Energy Storage Power Station Demand** no increase in demand shall occur while the **Transmission System Frequency** is below 49.5 Hz and no decrease in demand shall occur while the **Transmission System Frequency** is above 50.5 Hz.

WFPS PPM 1.5.2 **ACTIVE POWER MANAGEMENT**

A ~~Wind-Farm PPM Control System~~ shall be installed by the ~~Controllable-WFPS~~ **Controllable PPM** to allow for the provision of **Active Power Control** and **Frequency Response** from the ~~Controllable-WFPS~~ **Controllable PPM**. The ~~Wind-Farm PPM Control System~~ and **Frequency Response System** shall provide the functionality as specified in this section ~~WFPS PPM~~1.5.2.

WFPS PPM 1.5.2.1 **Active Power Control**

The ~~Wind-Farm PPM Control System~~ shall be capable of operating each **WTG Generation Unit** at a reduced level if the ~~Controllable-WFPS's~~ **Controllable PPM's** **Active Power** output has been restricted by the **TSO**. In this **Active Power Control Mode**, the ~~Wind-Farm PPM Control System~~ shall be capable of receiving an on-line **Active Power Control Set-point** sent by the **TSO** and shall commence implementation of the set-point within 10 seconds of receipt of the signal from the **TSO**. The rate of change of output to achieve the **Active Power Control Set-point** should be the **Active Power Control Set-Point Ramp Rate** setting of the ~~Wind-Farm PPM Control System~~, as advised by the **TSO**, as per ~~WFPS PPM~~1.5.4. The **TSO** acknowledges that if the

Active Power output of the ~~Controllable-WFPS~~ **Controllable PPM** is initially less than the **Design Minimum Operating Level**, and if the ~~Controllable-WFPS~~ **Controllable PPM** is expected to increase its **Active Power** output, then it may not be able to achieve the specified ramp rate at first, due to **WTGs Generation Units** going through a start-up sequence. In such a case, **WTGs Generation Units** shall start up as quickly as the technology allows, and in any case, not longer than three minutes from the time the **Active Power Control Set-point** was received.

~~WFPS PPM~~ 1.5.3 **FREQUENCY RESPONSE**

~~WFPS PPM~~ 1.5.3.1 In **Wind Resource Following Mode**, the **Frequency Response System** shall have the capabilities as displayed in the *Power-Frequency Response Curve* in *Figures* ~~WFPS PPM~~ 1.2, where the power and frequency ranges required for points A, B, C, D, E are defined below in *Table* ~~WFPS PPM~~ 1.1 and *Table* ~~WFPS PPM~~ 1.2. The **Frequency Response System** shall adjust the **Active Power** output of the ~~Controllable-WFPS~~ **Controllable PPM** according to a **Governor Droop**, settable by the **TSO** in a range from 2% to 10% and defaulting to 4%, when operating in the ranges outside the deadband range F_B - F_C in the *Power-Frequency Response Curve*. ~~Controllable-WFPS~~ **Controllable PPM Frequency Response** and **Governor Droop** shall be calculated with respect to **Registered Capacity**.

~~WFPS PPM~~ 1.5.3.2 When in **Active Power Control Mode**, the ~~Controllable-WFPS~~ **Controllable PPM** shall always operate in **Frequency Sensitive Mode** with a **Governor Droop** as set out in ~~WFPS PPM~~ 1.5.3.1 and with a deadband of +/-15mHz or as otherwise agreed with the **TSO**.

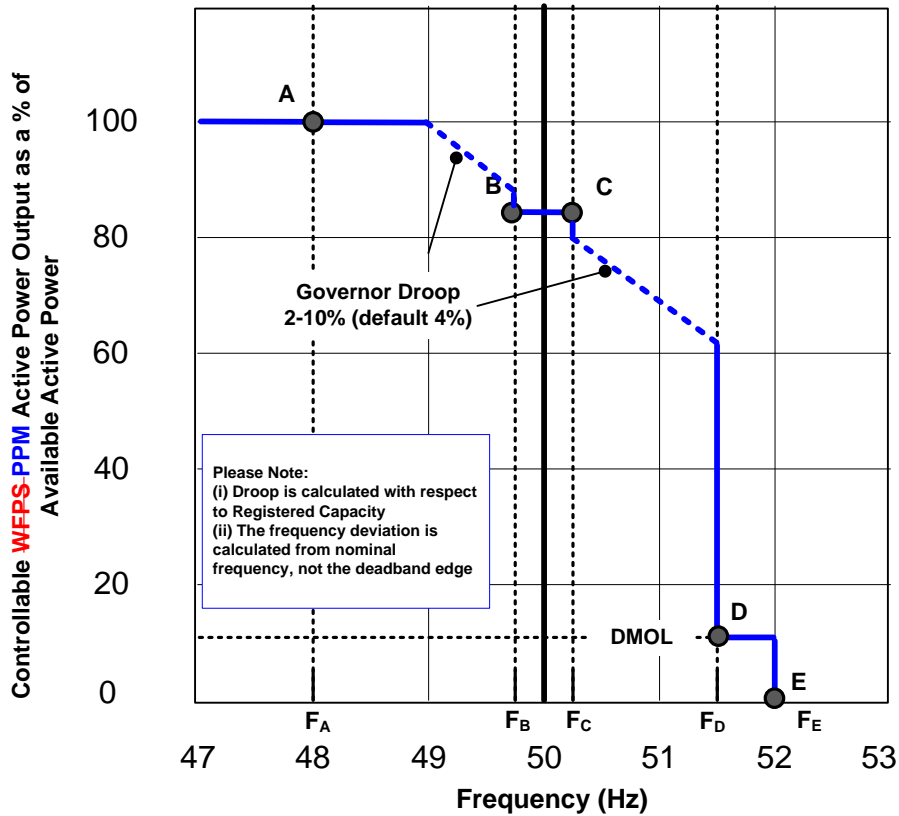

Figure WFPS PPM 1.2 –Example of Power-Frequency Response Curve for Wind Resource Following Mode

WFPS PPM 1.5.3.3 When acting to control Transmission System Frequency, the Controllable WFPS Controllable PPM shall provide at least 60% of its expected additional Active Power response within 5 seconds, and 100% of its expected additional Active Power response within 15 seconds of the start of the Transmission System Frequency excursion outside the range F_B - F_C , or in the case of a Controllable WFPS Controllable PPM in Active Power Control Mode, when the Transmission System Frequency goes outside the deadband set out in WFPS PPM 1.5.3.2.

WFPS PPM 1.5.3.4 When the Transmission System Frequency is in the range F_C - F_D , the Controllable WFPS Controllable PPM shall ensure that its Active Power Output does not increase beyond the Active Power value of the Controllable WFPS Controllable PPM when the Transmission System Frequency first exceeded F_C , due to an increase in Available Active Power in that period.

WFPS PPM 1.5.3.5 If the Frequency drops below F_A , then the Frequency Response System shall act to maximise the Active Power output of the Controllable WFPS Controllable PPM, irrespective of the Governor Droop Setting. If the Frequency rises above F_D , then the Frequency Response System shall act to reduce the Active Power output of the Controllable WFPS Controllable PPM to its DMOL value. If the Frequency rises above

F_E , then the **Frequency Response System** shall act to reduce the **Active Power** output of the **Controllable-WFPS Controllable PPM** to zero. Any **WTG Generation Unit** which has disconnected shall be brought back on load as fast as technically feasible, provided the **Transmission System Frequency** has fallen below 50.2 Hz.

WFPS PPM 1.5.3.6 Points 'A', 'B', 'C', 'D' and 'E' shall depend on a combination of the **Transmission System Frequency, Active Power and Active Power Control Set-point** settings. These settings may be different for each **Controllable-WFPS Controllable PPM** depending on system conditions and **Controllable-WFPS Controllable PPM** location. These settings are defined in *Table WFPS PPM1.1* below.

Point	Transmission System Frequency (Hz)	Controllable-WFPS Controllable PPM Active Power Output (% of Available Active Power)
A	F_A	P_A
B	F_B	Minimum of : P_B or Active Power Control Set-point (converted to a % of Available Active Power)
C	F_C	Minimum of: P_C or Active Power Control Set-point (converted to a % of Available Active Power)
D	F_D	Minimum of: P_D or Active Power Control Set-point (converted to a % of Available Active Power)
E	F_E	$P_E = 0 \%$

Table WFPS PPM1.1: Transmission System Frequency and % Available Active Power Settings for the Points 'A', 'B', 'C', 'D' and 'E' illustrated in Figure WFPS PPM1.2

Two settings for each of $F_A, F_B, F_C, F_D, F_E, P_A, P_B, P_C, P_D$ and P_E shall be specified by the **TSO** at least 120 **Business Days** prior to the **Controllable-WFPS's Controllable PPM's** scheduled **Operational Date** (refer to WFPS1.5.3.11 below). The **Controllable-WFPS Controllable PPM** shall be responsible for implementing the appropriate settings during **Commissioning**.

WFPS PPM 1.5.3.7 The table below, *Table WFPS PPM1.2*, shows the **Transmission System Frequency and Active Power** ranges for $F_A, F_B, F_C, F_D, F_E, P_A, P_B, P_C, P_D$ and P_E .

	Transmission System		Available Active Power (%)

FORM GC1

	Frequency (Hz)		
			Registered Capacity ≥ 5 MW
F_A	47.0-49.5	P_A	50-100
F_B	49.5-50	P_B	15-100
F_C	50-50.5	P_C	
F_D	50.5-52.0	P_D	15-100 but not less than DMOL
F_E		P_E	0

Table WFPS1.2: Transmission System Frequency & Active Power ranges

appropriate to Figure ~~WFPS~~ PPM 1.2.

For the **Transmission System Frequency** values in Table ~~WFPS~~ PPM 1.2 above, $F_A \leq F_B \leq F_C \leq F_D \leq F_E$.

~~WFPS~~ PPM 1.5.3.8 Alterations to the ~~Controllable-WFPS's~~ **Controllable PPM's Active Power** output, triggered by **Transmission System Frequency** changes, shall be achieved by proportionately altering the **Active Power** output of all available ~~WTGs~~ **Generation Units** as opposed to switching individual ~~WTGs~~ **Generation Units** on or off, insofar as possible.

~~WFPS~~ PPM 1.5.3.9 No time delays, such as moving average frequency filters, other than those necessarily inherent in the design of the **Frequency Response System** shall be introduced. The **Frequency Response System** shall continuously monitor the **Transmission System Frequency** in order to continuously determine the ~~Controllable-WFPS's~~ **Controllable PPM's** appropriate **Active Power** output by taking account of the ~~Controllable-WFPS's~~ **Controllable PPM's Available Active Power** or **Controlled Active Power**.

~~WFPS~~ PPM 1.5.3.10 If the **Transmission System Frequency** rises to a level above 'D'-'E', as defined by the *Power-Frequency Response Curve* in Figure ~~WFPS~~ PPM 1.2, the **TSO** accepts that ~~WTGs~~ **Generation Units** may disconnect. Any ~~WTG~~ **Generation Unit** which has disconnected shall be brought back on load as fast as technically feasible (provided the **Transmission System Frequency** has fallen below 50.2 Hz).

~~WFPS~~ PPM 1.5.3.11 **Procedure for Setting and Changing the Power-Frequency Response Curves**

Two *Power-Frequency Response Curves* (Curve 1 and Curve 2) shall be specified by the **TSO** at least 120 **Business Days** prior to the ~~Controllable-WFPS's~~ **Controllable PPM's** scheduled **Operational Date**. The ~~Controllable-WFPS~~ **Controllable PPM** shall be responsible for implementing the appropriate settings during **Commissioning**. The **Frequency Response System** shall be required to change between the two curves within one minute from receipt of the appropriate signal from the **TSO**. The **TSO** shall give the ~~Controllable-WFPS~~ **Controllable PPM** a minimum of two weeks' notice if

changes to either of the curve's parameters (*i.e.* F_A , F_B , F_C , F_D , F_E , P_A , P_B , P_C , P_D or P_E), are required. The ~~Controllable-WFPS~~ **Controllable PPM** shall formally confirm that any requested changes have been implemented within two weeks of receiving the TSO's formal request.

~~WFPS PPM~~ 1.5.4 RAMP RATES

~~WFPS PPM~~ 1.5.4.1 The ~~Wind-Farm-Control-System~~ **PPM Control System** shall be capable of controlling the ramp rate of its **Active Power** output. There shall be three ramp rate capabilities, designated ~~Wind Resource~~ **Following Ramp Rate**, **Active Power Control Set-Point Ramp Rate**, and **Frequency Response Ramp Rate**. The ~~Wind-Farm-Control-System~~ **PPM Control System** shall operate the ramp rates with the following order of priority (high to low): **Frequency Response Ramp Rate**; **Active Power Control Set-Point Ramp Rate**; ~~Wind Resource~~ **Following Ramp Rate**. The ~~Wind Resource~~ **Following Ramp Rate** shall be used during **Start-Up**, normal operation, and **Shutdown**. The TSO shall specify the ~~Wind Resource~~ **Following Ramp Rate** and the **Active Power Control Set-Point Ramp Rate** in percentage of **Registered Capacity** per minute. The **Frequency Response Ramp Rate** shall be the maximum possible ramp rate of the ~~Controllable-WFPS~~ **Controllable PPM** agreed with the TSO and with the characteristics as set out in WFPS1.5.3.1. The TSO acknowledges that rapidly changing ~~wind-speeds~~ **resource availability** may cause temporary deviations from the ramp rate settings of the ~~Controllable-WFPS~~ **Controllable PPM**, but these deviations should not be allowed to exceed 3% of **Registered Capacity**.

~~WFPS PPM~~ 1.5.4.2 It shall be possible to vary the ~~Wind Resource~~ **Following Ramp Rate** and the **Active Power Control Set-Point Ramp Rate** each independently over a range between 1% and 100% of **Registered Capacity** per minute.

~~WFPS PPM~~ 1.5.4.3 Procedure for Setting and Changing the Ramp Rate Control

The ramp rate settings shall be specified by the TSO at least 120 **Business Days** prior to the ~~Controllable-WFPS's~~ **Controllable PPM's** scheduled **Operational Date**. The ~~Controllable-WFPS~~ **Controllable PPM** shall be responsible for implementing the appropriate settings during **Commissioning**. The ramp rate settings may need to be changed from time to time depending on system needs. The TSO shall give the ~~Controllable-WFPS~~ **Controllable PPM** a minimum of two weeks' notice if a change is required. The ~~Controllable-WFPS~~ **Controllable PPM** shall formally confirm that any requested changes have been implemented within two weeks of receiving the TSO's formal request.

~~WFPS PPM~~ 1.6 TRANSMISSION SYSTEM VOLTAGE REQUIREMENTS

~~WFPS PPM~~ 1.6.1 TRANSMISSION SYSTEM VOLTAGE RANGE

~~Controllable-WFPSs~~ **Controllable PPMs** shall remain continuously connected to the **Transmission System** at maximum **Available Active Power** or **Controlled Active Power** output for normal and disturbed system conditions and for step changes in **Transmission System Voltage** of up to 10 %. The following are the ranges which may arise during **Transmission System** disturbances or following transmission faults:

- (a) 400 kV system: 350 kV to 420 kV;
- (b) 220 kV system: 200 kV to 245 kV;
- (c) 110 kV system: 99 kV to 123 kV.

WFPS PPM 1.6.2 **AUTOMATIC VOLTAGE REGULATION**

WFPS PPM 1.6.2.1 ~~Controllable-WFPSs~~ **Controllable PPMs** shall have a continuously-variable and continuously-acting **Voltage Regulation System** with similar response characteristics to a conventional **Automatic Voltage Regulator** and shall perform generally as described in BS4999 part 140, or equivalent European Standards.

WFPS PPM 1.6.2.2 Under steady state conditions, the **Voltage Regulation System** shall be capable of implementing the following **Reactive Power** control modes which shall be available to the **TSO**:

- a) The ~~Controllable-WFPS~~ **Controllable PPM** shall be capable of receiving a **Power Factor** control (PF) set-point to maintain the **Power Factor** set-point at the **Connection Point**;
- b) The ~~Controllable-WFPS~~ **Controllable PPM** shall be capable of receiving a **Reactive Power** control (Q) set-point to maintain the **Reactive Power** set-point at the **Connection Point**;
- c) The ~~Controllable-WFPS~~ **Controllable PPM** shall be capable of receiving a **Voltage Regulation (kV) Set-point** for the **Voltage** at the **Connection Point**. The **Voltage Regulation System** shall act to regulate the **Voltage** at this point by continuous modulation of the ~~Controllable-WFPS's~~ **Controllable PPM's Reactive Power** output, without violating the **Voltage Step Emissions** limits as set out in the IEC standard 61000-3-7:1996 *Assessment of Emission limits for fluctuating loads in MV and HV power systems*. The ~~Controllable-WFPS's~~ **Controllable PPM's Reactive Power** output shall be zero when the **Voltage** at the **Connection Point** is equal to the **Voltage Regulation Set-point**.

A change to the **Power Factor** control (PF) set-point, **Reactive Power** control (Q) set-point or **Voltage Regulation (kV) Set-Point** shall be implemented by the ~~Controllable-WFPS~~ **Controllable PPM** within 20

seconds of receipt of the appropriate signal from the TSO, within its reactive power capability range as specified in **WFPS PPM** 1.6.3.

WFPS PPM 1.6.2.3 The **Voltage Regulation System Slope Setting** shall be capable of being set to any value between 1 % and 10 %. The setting shall be specified by the TSO at least 120 **Business Days** prior to the ~~Controllable-WFPS's~~ **Controllable PPM's** scheduled **Operational Date**. The ~~Controllable-WFPS~~ **Controllable PPM** shall be responsible for implementing the appropriate settings during **Commissioning**. The slope setting may be varied from time to time depending on **Transmission System** needs. The TSO shall give the ~~Controllable-WFPS~~ **Controllable PPM** a minimum of two weeks' notice if a change is required. The ~~Controllable-WFPS~~ **Controllable PPM** shall formally confirm that any requested changes have been implemented within two weeks of receiving the TSO's formal request.

WFPS PPM 1.6.2.4 The speed of response of the **Voltage Regulation System** shall be such that, following a step change in **Voltage** at the **Connection Point** the ~~Controllable-WFPS~~ **Controllable PPM** shall achieve 90 % of its steady-state **Reactive Power** response within 1 second. The response may require a transition from maximum **Mvar** production to maximum **Mvar** absorption or vice-versa.

WFPS PPM 1.6.2.5 *Figure ~~WFPS-PPM~~1.3 shows the relevant points appropriate to the **Voltage Regulation System** for a ~~Controllable-WFPS~~ **Controllable PPM**. X is the HV side of the **WTG Generation Unit** transformer, Y is the lower voltage side of the **Grid Connected Transformer** and Z is the **Connection Point**.*

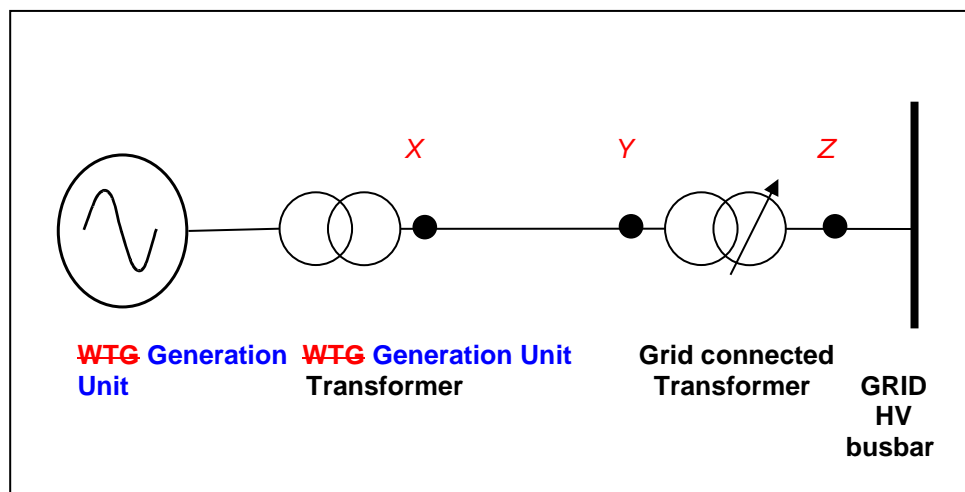

*Figure ~~WFPS PPM~~1.3 - Locations for **Voltage Regulation** set-point (Z) and the **Power Factor** range (Y). The HV side of the **WTG Generation Unit** transformer is (X).*

WFPS PPM 1.6.3 **REACTIVE POWER CAPABILITY**

WFPS PPM 1.6.3.1 ~~Controllable WFPSs~~ **Controllable PPMs** operating in **Power Factor** control mode, **Voltage Control** mode or constant **Reactive Power** mode shall be at least capable of operating at any point within the P-Q capability ranges illustrated in *Figure ~~WFPS-PPM~~11.4*, as measured at the **Connection Point** over the normal and disturbed **Transmission System Voltage** ranges specified in CC.8.3.2.

Referring to *Figure ~~WFPS-PPM~~11.4*:

Point A represents the minimum Mvar absorption capability of the ~~Controllable WFPS~~ **Controllable PPM** at 100% **Registered Capacity** and is equivalent to 0.95 power factor leading;

Point B represents the minimum Mvar production capability of the ~~Controllable WFPS~~ **Controllable PPM** at 100% **Registered Capacity** and is equivalent to 0.95 power factor lagging;

Point C represents the minimum Mvar absorption capability of the ~~Controllable WFPS~~ **Controllable PPM** at 12% **Registered Capacity** and is equivalent to the same **Mvar** as Point A;

Point D represents the minimum Mvar production capability of the ~~Controllable WFPS~~ **Controllable PPM** at 12% **Registered Capacity** and is equivalent to the same **Mvar** as Point B;

Point E represents the minimum Mvar absorption capability of the ~~Controllable WFPS~~ **Controllable PPM** at the cut-in speed of the individual **WTGs Generation Units**;

Point F represents the minimum Mvar production capability of the ~~Controllable WFPS~~ **Controllable PPM** at the cut-in speed of the individual **WTGs Generation Units**;

The **TSO** accepts that the values of Points E and F may vary depending on the number of **WTGs Generation Units** generating electricity in a low-wind resource scenario;

Figure WFPS1.4 represents the minimum expected **Reactive Power** capabilities of the ~~Controllable WFPS~~ **Controllable PPM**. The ~~Controllable WFPS~~ **Controllable PPM** is obliged to tell the **TSO/DSO** if it can exceed these capabilities, and submit the actual P-Q capability diagram based upon the installed plant and **Collector Network** characteristics to the **TSO** during **Commissioning**.

The **Grid Connected Transformer** tap changing range must be capable of ensuring nominal voltage at point Y for any **Voltage** at the **Connection Point** (Point Z) within the ranges specified in ~~WFPS PPM~~1.6.1.

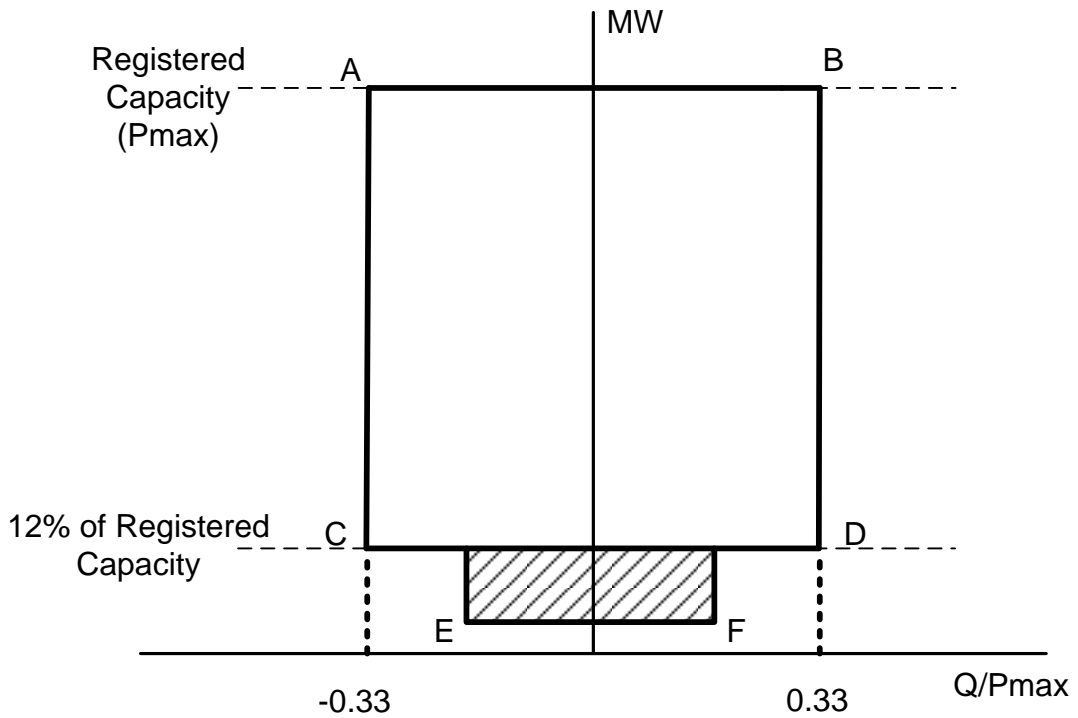

Figure ~~WFPS PPM~~1.4 – Minimum Reactive Power Capability of ~~Controllable~~ **Controllable PPM**

~~WFPS PPM~~ 1.6.3.2 For ~~Controllable~~ **Controllable PPMs** where the **Connection Point** is remote from the **Grid Connected Transformer**, any supplementary **Reactive Power** compensation required to offset the **Reactive Power** demand of the HV line, or cable, between the **Connection Point** and the ~~Controllable~~ **Controllable PPM** shall be identified during the **TSO's Connection Offer** process.

~~WFPS PPM~~ 1.6.3.3 The total charging of the ~~Controllable~~ **Controllable PPM Collector Network** during low load operation (below 12%) shall be examined during the **TSO's Connection Offer** process. If during this examination it is identified that this charging may cause the voltage on the **Transmission System** to be outside the **Transmission System Voltage** ranges, as specified in ~~WFPS PPM~~1.6.1, then the **Reactive Power** requirements will need to be altered.

~~WFPS PPM~~ 1.6.4 **VOLTAGE STEP EMISSIONS**

IEC 61000-3-7:1996 *Assessment of Emission limits for fluctuating loads in MV and HV power systems*, gives a table of the emission limits for **Voltage** changes as a function of the number of changes, R, per hour. This standard shall also apply to ~~Controllable~~ **Controllable PPMs**.

~~WFPS PPM~~ 1.6.5 **CONTROLLABLE** ~~WFPS'S~~ **CONTROLLABLE PPM'S** **GRID CONNECTED TRANSFORMER**

WFPS PPM 1.6.5.1 All relevant references in the **Grid Code** to **Generator Transformers** shall be interpreted to mean the ~~Controllable-WFPS's~~ **Controllable PPM's Grid Connected Transformer** rather than the individual **WTG Generation Unit** transformers. For ~~Controllable-WFPSs~~ **Controllable PPMs** where the **Connection Point** is remote from the ~~Controllable-WFPS~~ **Controllable PPM**, **Grid Connected Transformer** shall be interpreted to mean the HV transformer located at the ~~Controllable-WFPS~~ **Controllable PPM**.

WFPS PPM 1.6.5.2 ~~Controllable-WFPSs~~ **Controllable PPMs** shall provide on-load tap-changing (OLTC) facilities for all **Grid Connected Transformers**. All ~~Controllable-WFPSs~~ **Controllable PPMs** shall liaise with the **TSO** on the design specification for the performance of the tap-changing facility of the **Grid Connected Transformer**.

WFPS PPM 1.6.5.3 The ~~Controllable-WFPS's~~ **Controllable PPM's** **Grid Connected Transformers** may be connected either:

- (a) in delta on the lower voltage side and in star (with the star point or neutral brought out) on the HV side; or
- (b) in star on both HV and lower voltage sides with a delta tertiary winding provided.

WFPS PPM 1.7 **SIGNALS, COMMUNICATIONS & CONTROL**

WFPS PPM 1.7.1 **SIGNALS FROM THE ~~CONTROLLABLE-WFPS~~ CONTROLLABLE PPM TO THE TSO**

Signals from ~~Controllable-WFPSs~~ **Controllable PPMs** to the **TSO** shall be broken up into a number of logical groups. There shall be different requirements for ~~Controllable-WFPSs~~ **Controllable PPMs** depending on the ~~Controllable-WFPS's~~ **Controllable PPM's MEC**. The following groups shall apply:

- *Signals List #1* - applies to all ~~Controllable-WFPSs~~ **Controllable PPMs**;

In addition, ~~Controllable-WFPSs~~ **Controllable PPMs** shall be required to provide signals from *Signals Lists 2, 3, 4 and/or 5*. These lists relate to:

- *Signals List #2* - Meteorological Data;
- *Signals List #3* - Availability Data;
- *Signals List #4* - Active Power Control Data;
- *Signals List #5* - Frequency Response System Data.

WFPS PPM 1.7.1.1 Signals List #1

The ~~Controllable-WFPS~~ **Controllable PPM** shall make the following signals available at the designated **TSO Telecommunication Interface Cabinet** for that ~~Controllable-WFPS~~ **Controllable PPM**:

- a) **Active Power** output (MW) at the lower voltage side of the **Grid Connected Transformer**;
- b) **Reactive Power** output/demand (+/-Mvar) at the lower voltage side of the **Grid Connected Transformer**;
- c) Voltage (in kV) at the lower voltage side of the **Grid Connected Transformer**;
- d) **Available Active Power** (MW) at the lower voltage side of the **Grid Connected Transformer**;
- e) **Grid Connected Transformer** tap positions;
- f) **Voltage Regulation Set-point** (in kV);
- g) On/off status indications for all **Reactive Power** devices exceeding 5 Mvar¹;
- h) Circuit-breaker and disconnect position indication shall be required. These may include indications from MV circuit-breakers on individual **WTG Generation Unit** circuits. Signals from individual **WTG Generation Unit** circuit-breakers shall not be required. The actual circuit-breaker and disconnect signals required shall be specified by the **TSO** at least 120 **Business Days** prior to the ~~Controllable-WFPS's~~ **Controllable PPM's** scheduled **Operational Date**;
- i) A minimum of four sets of normally open potential free auxiliary contacts in each **Grid Connected Transformer** lower voltage bay for fault indications; and
- j) On/off status of **TSO** remote control enable switch, which disables the ability of the **TSO** to send commands to the ~~Controllable-WFPS~~ **Controllable PPM**.

For the ~~Controllable-WFPS's~~ **Controllable PPM's** where the **Connection Point** is at the HV side of the **Grid Connected Transformer**, signals a), b) and c) above will also be required from the HV side of the **Grid Connected Transformer**.

WFPS PPM 1.7.1.2 Signals List #2

WFPS PPM 1.7.1.2.1 Controllable WFPSs with a **MEC** in excess of 10 MW shall make the following meteorological data signals available at the designated **TSO Telecommunication Interface Cabinet** for that **Controllable WFPS**:

- | | <u>[Units, Range]</u> |
|---|-----------------------|
| a) Wind speed (at hub height) - measurand signal; | [m/s, 0-70] |
| b) Wind direction (at hub height) - measurand signal; | [deg, 0-360] |
| c) Air temperature- measurand signal; | [deg C, -40-70] |

¹ Typically the position indication from capacitor/ SVC circuit breakers

d) Air pressure- measurand signal. [mBar, 735-1060]

WFPS PPM 1.7.1.2.2 The meteorological data signals shall be provided by a dedicated **Meteorological Mast** located at the **Controllable WFPS** site or, where possible and preferable to do so, data from a means of the same or better accuracy. For **Controllable WFPSs** where the **WTG** are widely dispersed over a large geographical area and rather different weather patterns are expected for different sections of the **Controllable WFPS**, the meteorological data shall be provided from a number of individual **Meteorological Masts**, or where possible and preferable to do so, data from a source of the same or better reliability for groups of **WTG** (e.g. 1 set of meteorological data for each group of XX **WTG** within the **Controllable WFPS**). It is expected that **WTG** within an individual group shall demonstrate a high degree of correlation in **Active Power** output at any given time. The actual signals required shall be specified by the **TSO** at least 120 **Business Days** prior to the **Controllable WFPS's** scheduled **Operational Date**.

PPM 1.7.1.2.3 **Controllable PPMs**, in excess of 5 MW, with the exception of **Controllable WFPSs**, shall make relevant meteorological data signals available, which may include but are not limited to solar irradiance and tidal streams, at the designated **TSO Telecommunication Interface Cabinet** for that **Controllable PPM** as agreed with the **TSO**. The actual signals required shall be specified by the **TSO** at least 120 **Business Days** prior to the **Controllable PPM's** scheduled **Operational Date**.

PPM 1.7.1.2.4 The meteorological data signals shall be provided by a measurement device located at the **Controllable PPM** site, the exception of **Controllable WFPS** sites, as defined by the **TSO**. All meteorological data signals shall at a minimum meet accuracy levels defined by the **TSO**. For **Controllable PPMs**, with the exception of **Controllable WFPSs**, where the **Generation Units** are widely dispersed over a large geographical area and rather different weather patterns are expected for different sections of the **Controllable PPM**, the meteorological data shall be provided from a number of individual sources. It is expected that **Generation Units** within an individual group shall demonstrate a high degree of correlation in **Active Power** output at any given time. The actual signals required shall be specified by the **TSO** at least 120 **Business Days** prior to the **Controllable PPM's** scheduled **Operational Date**.

WFPS PPM 1.7.1.3 *Signals List #3*

WFPS PPM 1.7.1.3.1 **Controllable WFPSs** with a **MEC** in excess of 10 MW shall make the following signals available at the designated **TSO Telecommunication Interface Cabinet** for that **Controllable WFPS**:

a) **Controllable WFPS Availability** (0-100 % signal);

FORM GC1

- b) Percentage of **WTG** shutdown due to high wind-speed conditions (0-100 %);
- c) Percentage of **WTG** not generating due low wind-speed shutdown (0-100 %).

WFPS PPM 1.7.1.3.2 For **Controllable WFPSs** with a **MEC** in excess of 10 MW, where the **WTG** are widely dispersed over a large geographical area and rather different weather patterns are expected for different sections of the **Controllable WFPS**, the above data set (ref. WFPS1.7.1.3.1) shall be provided for a number of groups of **WTG** (e.g. 1 signal for each group of XX **WTG** within the **Controllable WFPS**). It is expected that **WTG** within an individual group shall demonstrate a high degree of correlation in **Active Power** output at any given time. The actual signals required shall be specified by the **TSO** at least 120 **Business Days** prior to the **Controllable WFPS's** scheduled **Operational Date**.

PPM 1.7.1.3.3 Controllable PPMs, with a **MEC** in excess of 5 MW, with the exception of **Controllable WFPSs**, shall make the following signals available at the designated **TSO Telecommunication Interface Cabinet** for that **Controllable PPM**:

- a) **Controllable PPM Availability** (0-100 % signal);
- b) Percentage of **Generation Unit** shutdown due to high resource conditions (0-100 %);
- c) Percentage of **Generation Unit** not generating due to low resource conditions (0-100 %).

PPM 1.7.1.3.4 For **Controllable PPMs**, with an **MEC** in excess of 5 MW, with the exception of **Controllable WFPSs**, where the **Generation Units** are widely dispersed over a large geographical area and rather different weather patterns are expected for different sections of the **Controllable PPM**, the above data set (ref. PPM 1.7.1.3.3) shall be provided for a number of groups of **Generation Units** (e.g. 1 signal for each group of XX **Generation Units** within the **Controllable PPM**). It is expected that **Generation Units** within an individual group shall demonstrate a high degree of correlation in **Active Power** output at any given time. The actual signals required shall be specified by the **TSO** at least 120 **Business Days** prior to the **Controllable PPM's** scheduled **Operational Date**.

WFPS PPM 1.7.1.4 Signals List #4

The ~~Controllable WFPS~~ **Controllable PPM** shall make the following signals available at the designated **TSO Telecommunication Interface Cabinet** for that ~~Controllable WFPS~~ **Controllable PPM**:

- a) ~~Controllable WFPS~~ **Controllable PPM Active Power Control Set-point** value (MW);
- b) ~~Controllable WFPS~~ **Controllable PPM Active Power Control** status indication (ON/OFF).

WFPS PPM 1.7.1.5 Signals List #5

The ~~Controllable-WFPS~~ **Controllable PPM** shall make the following signals available at the designated **TSO Telecommunication Interface Cabinet** for that ~~Controllable-WFPS~~ **Controllable PPM**:

- a) **Frequency Response System** mode signal (i.e. *Power-Frequency Response Curve 1 or 2*);
- b) **Frequency Response System** status indication (ON/OFF).
- c) **Frequency Response System Governor Droop** value.

WFPS PPM 1.7.1.6 Time Delays and Data Quality

WFPS PPM 1.7.1.6.1 Digital signal changes from the ~~Controllable-WFPS~~ **Controllable PPM** shall be relayed to the **TSO Telecommunication Interface Cabinet** within 1 second of the associated change of state event. Analogue signal changes shall be relayed within 5 seconds and with an error of 0.5% or less, with the exception of the Meteorological Data required as per ~~WFPS PPM 1.7.1.2-1~~, which shall be updated within 5 seconds and with an error of 2.5% or less.

WFPS PPM 1.7.2 CONTROL SIGNALS FROM THE TSO TO ~~CONTROLLABLE-WFPS~~ CONTROLLABLE PPM

WFPS PPM 1.7.2.1 The control signals described in WFPS1.7.2 shall be sent from the **TSO** to the ~~Controllable-WFPS~~ **Controllable PPM**. The ~~Controllable-WFPS~~ **Controllable PPM** shall be capable of receiving these signals and acting accordingly.

WFPS PPM 1.7.2.2 Active Power Control

An **Active Power Control Set-point** signal shall be sent by the **TSO** to the ~~Wind-Farm~~ **PPM Control System**. This set-point shall define the maximum **Active Power** output permitted from the ~~Controllable-WFPS~~ **Controllable PPM**. The ~~Wind-Farm~~ **PPM Control System** shall be capable of receiving this signal and acting accordingly to achieve the desired change in **Active Power** output. This signal shall be in the form of a single analogue value and a strobe pulse to enable.

The ~~Controllable-WFPS~~ **Controllable PPM** is required to make it possible for the **TSO** to remotely enable/ disable the **Active Power Control** function in the ~~Wind-Farm~~ **PPM Control System**. The associated status indication is described in ~~WFPS PPM 1.7.1.4~~.

WFPS PPM 1.7.2.3 Frequency Response

This signal shall be sent by the **TSO** to the ~~Controllable-WFPS~~ **Controllable PPM** in the event that a change from *Power-Frequency Response Curve 1* to *Power Frequency Response Curve 2*, or vice versa, is required.

The ~~Controllable-WFPS~~ **Controllable PPM** is required to make it possible for the **TSO** to remotely enable/ disable the **Frequency Response System**. The associated status indication is described in WFPS1.7.1.5.

The ~~Controllable-WFPS~~ **Controllable PPM** shall make it possible for the **TSO** to set the **Governor Droop** value of the **Frequency Response System** in values from 2% to 10%.

WFPS PPM 1.7.2.4 Voltage Regulation

This signal shall allow the **TSO** to send a **Voltage Regulation Set-point** for **Voltage Regulation** purposes. This signal shall be in the form of a single analogue value and a strobe pulse to enable.

WFPS PPM 1.7.2.5 Black Start Shutdown

Means shall be provided by the ~~Controllable-WFPS~~ **Controllable PPM** to facilitate the disconnection of the ~~Controllable-WFPS~~ **Controllable PPM** by the **TSO** and to also prevent re-connection in the event of **Black Start**. The **TSO** shall send a **Black Start Shutdown** signal and upon receipt, the ~~Controllable-WFPS~~ **Controllable PPM** shall be required to trip the circuit-breaker(s) at the ~~Controllable-WFPS's~~ **Controllable PPM's Connection Point** and shutdown the ~~Controllable-WFPS~~ **Controllable PPM** in a controlled manner. The precise circuit-breakers for which this facility shall be provided shall be specified by the **TSO** at least 120 **Business Days** prior to the ~~Controllable-WFPS's~~ **Controllable PPM's** scheduled **Operational Date**. ~~Controllable-WFPSs~~ **Controllable PPMs** may only be reconnected (i.e. made live) when the **Network** is fully restored following instruction from the **TSO**² and only earlier if the **TSO** deems it acceptable to do so.

WFPS PPM 1.7.2.6 Time Delays and Data Quality

WFPS PPM 1.7.2.6.1 Digital output commands from the **TSO Telecommunication Interface Cabinet** shall be relayed to the ~~Controllable-WFPS~~ **Controllable PPM** equipment within 1 second. Set-point output signals shall be relayed within 5 seconds and with an error of 0.5% or less.

WFPS PPM 1.7.3 RESPONSIBLE OPERATOR

A designated **Responsible Operator** shall be contactable by the **TSO** at all times to discuss operational matters without undue delay and in any case within 15 minutes. Following a request from the **TSO**, the **Responsible Operator** shall be present at the ~~Controllable-WFPS's~~ **Controllable PPM's Connection Point** without undue delay and in any case within one hour and shall be capable of taking any required appropriate

² Typically this instruction will be in the form of a Blackstart Shutdown OFF command

actions. The **Responsible Operator** shall be contactable 24 hours a day, 365 days a year.

WFPS PPM 1.7.4 DATA AND COMMUNICATIONS SPECIFICATIONS

WFPS PPM 1.7.4.1 The location of the **TSO Telecommunication Interface Cabinet** shall be agreed between the **TSO** and the ~~Controllable-WFPS~~ **Controllable PPM** at least 120 **Business Days** prior to the ~~Controllable-WFPS's~~ **Controllable PPM's** scheduled **Operational Date**. A standard interface for signals will be made available to the ~~Controllable-WFPS~~ **Controllable PPM** by the **TSO**.

WFPS PPM 1.7.4.2 The necessary communications links, communications protocol and an individual ~~Controllable-WFPS~~ **Controllable PPM** signal list shall be specified by the **TSO** at least 120 **Business Days** prior to the ~~Controllable-WFPS's~~ **Controllable PPM's** scheduled **Operational Date**. Current applicable standards shall apply and the accuracy class for signals shall comply with the prevailing European Standard at that time.

WFPS PPM 1.7.4.3 For loss of communications links, persistence (i.e. continuing to operate with the most recent data set) shall be used in terms of set-points until the designated **Responsible Operator** has been contacted by the **TSO**.

WFPS PPM 1.7.4.4 If **Active Power Control, Frequency Response** or **Voltage Regulation** facilities for the **Controllable WFPS** become unavailable, the ~~Controllable-WFPS~~ **Controllable PPM** shall contact the **TSO** without undue delay.

WFPS PPM 1.7.4.5 Where signals or indications required to be provided by the ~~Controllable-WFPS~~ **Controllable PPM** under ~~WFPS PPM~~1.7.1 and ~~WFPS PPM~~1.7.2 become unavailable or do not comply with applicable standards due to failure of the ~~Controllable-WFPS's~~ **Controllable PPM's** technical equipment or any other reason under the control of the ~~Controllable-WFPS~~ **Controllable PPM**, the ~~Controllable-WFPS~~ **Controllable PPM** shall, acting in accordance with **Good Industry Practice**, restore or correct the signals and/or indications as soon as possible.

WFPS PPM 1.7.5 WIND-POWER PPM RESOURCE FORECASTS

WFPS PPM 1.7.5.1 Should the **TSO** determine that ~~wind-power~~ resource forecasts as produced by the ~~Controllable-WFPS~~ **Controllable PPM** are required, the **TSO** shall inform the ~~Controllable-WFPS~~ **Controllable PPM** and the ~~wind-power~~ resource forecasts shall be provided by the ~~Controllable-WFPSs~~ **Controllable PPMs**. These forecasts, if required, shall be provided in a format and timescale as specified by the **TSO**, and by means of an **Electronic Interface** in accordance with the reasonable requirements of the **TSO's** data system.

WFPS PPM 1.7.5.2 ~~Controllable-WFPSs~~ **Controllable PPMs** shall engage fully with the **TSO** to ensure that the necessary information is available to the **TSO** for the production of ~~wind~~ **resource** generation forecasts with the appropriate level of accuracy by the **TSO**. Where this engagement involves the provision of data by the ~~Controllable-WFPS~~ **Controllable PPM** to the **TSO**, this data must be provided as soon as reasonably practicable, or in any event, within 60 business days of the date of the request.

WFPS PPM 1.7.6 ~~CONTROLLABLE-WFPS~~ **CONTROLLABLE PPM MW AVAILABILITY DECLARATIONS**

~~Controllable-WFPSs~~ **Controllable PPMs** shall submit ~~Controllable-WFPS~~ **Controllable PPM MW Availability Declarations** whenever changes in ~~Controllable-WFPS~~ **Controllable PPM Availability** occur or are predicted to occur. These declarations shall be submitted by means of an **Electronic Interface** in accordance with the reasonable requirements of the **TSO's** data system.