



**The EirGrid and SONI Implementation Approach to the  
SEM Committee Decision Paper SEM-15-071**

**“Process for the Calculation of Outturn Availability”**

**Version 2**

**March 2017**

## Contents

Executive Summary.....	2
Key Points.....	3
1. Background .....	6
2. Application of the SEMC Decision.....	6
3. Outturn Availability Connection Assets .....	6
4. Capital Outages .....	6
5. Annual Maintenance Outages .....	7
6. Definition of Annual Maintenance.....	7
7. The Five Designated Days of Annual Maintenance .....	7
Scheduling Designated Days .....	7
Generation Unit Initiated Outage Change Request .....	8
TSO or TAO Initiated Outage Change.....	8
8. Other Relevant Transmission Outages.....	9
9. The Fora .....	9
10. Outturn Availability Declarations.....	9
11. Application of the decision to both Transmission and Distribution Connected Facilities .....	10
Appendix 1: Example to demonstrate Annual Maintenance Outages .....	11
Appendix 2: Example to demonstrate Annual Maintenance Outages .....	13
Appendix 3: Example to demonstrate Transmission Outages for Capital Works.....	14
Appendix 4: Example to demonstrate a Generation Unit’s own Outage .....	15
Appendix 5: Example to demonstrate Other Relevant Transmission Outages .....	16
Appendix 6: Examples of allocation of Designated Days .....	17
Appendix 7: Outturn Availability “Quick Guide” Decision Matrix .....	19

## Executive Summary

The Single Electricity Market Committee (SEMC) decision SEM-15-071 “Process for the Calculation of Outturn Availability” was published on 29 September 2015.

In order to provide further clarity to the industry, EirGrid and SONI published “The EirGrid and SONI Implementation Approach to the SEM Committee Decision Paper SEM-15-071” on 10 February 2016 which clearly set out the system operators approach to implementation. This document has been updated (version 2) and is intended to clearly set out how the Transmission System Operators (TSOs) in collaboration with the Transmission Asset Owners (TAOs), intend to implement the SEMC Decision Paper SEM-15-071. This version 2 has been updated following the first full year of implementation of the decision and reflects the associated grid code modifications which are now in place.

As the transmission outage season is regarded as running on a calendar year basis the principles set out in this document apply from 1 January to 31 December each year.

The SEM-15-071 decision paper applies to both transmission and distribution connected Centrally Dispatched Generating Units and Controllable Wind Farm Power Stations which are disconnected as a direct result of a transmission outage scheduled by the TSO. Outages on the distribution system are not related to the decision paper.

This paper begins by highlighting the key points in relation to the TSO’s implementation approach and then continues to explain these points in more detail throughout the paper.

## Key Points

On 29 September 2015, the Single Electricity Market Committee (SEMC) published its decision paper SEM-15-071 on the “Process for the Calculation of Outturn Availability”. On 22 December 2015, the SEMC published an addendum paper SEM-15-106 confirming that the new arrangement will take effect from 1 January 2016. In response to this decision, EirGrid Plc and SONI Ltd, in their roles as Transmission System Operators (TSOs<sup>1</sup>) in Ireland and Northern Ireland respectively, in consultation with the Transmission Asset Owners<sup>2</sup> (TAOs), set out in this document how they are implementing the decision across Ireland and Northern Ireland. Version 1 of this paper was shared with the RAs in advance of publication and their comments were incorporated.

The principles of the TSOs’ implementation approach are as follows:

1. The SEM-15-071 decision paper applies to both transmission and distribution connected Centrally Dispatched Generating Units<sup>3</sup> (CDGUs) and Controllable Wind Farm Power Stations<sup>4</sup> (Controllable WFPS) (henceforth for the purposes of this paper known as a Generation Unit) which are disconnected as a direct result of a TSO scheduled outage of an *Outturn Availability Connection Asset(s)*. Outages on the distribution system are not related to the decision paper, and as such any distribution connected CDGU or Controllable WFPS shall be declared unavailable when disconnected due to a DSO outage.
2. An *Outturn Availability Connection Asset(s)* (OACAs) for the purposes of this interpretation of SEM-15-071 is defined as any equipment that is part of the Transmission System between and including the Connection Point and the busbar clamps at the Meshed Transmission Station for which the TSO schedules outages.
3. Each relevant Generation Unit affected by a transmission outage will declare their Availability as per the relevant Grid Code<sup>5</sup>, which require that the Generation Unit will declare Availability as zero during:
  - a. Up to five calendar days for TSO scheduled annual maintenance works on the Outturn Availability Connection Asset.
  - b. A period where work on the transmission system is being carried out that is related to the relevant Generation Unit.

---

<sup>1</sup> In this document the term ‘the TSO[s]’ is used from time to time as shorthand for EirGrid and SONI, in their role as Transmission System Operator in Ireland and Northern Ireland respectively; where the sense requires this should be read as EirGrid and/or SONI in the carrying out of their respective licenced functions.

<sup>2</sup> In this document the term ‘the TAO[s]’ is used from time to time as shorthand for ESB Networks (ESBN) and NIE Networks, in their role as Transmission Asset Owner in Ireland and Transmission Owner (TO) in Northern Ireland respectively; where the sense requires this should be read as ESBN and/or NIE Networks in the carrying out of their respective licenced functions.

<sup>3</sup> All capitalised terms are defined as per the relevant Grid Code, with the exception of acronyms and the terms Outturn Availability and Outturn Availability Connection Asset which are defined in this paper.

<sup>4</sup> A Controllable WFPS with a single connection point is for the purposes of Outturn Availability considered a Generation Unit.

<sup>5</sup> Generators connected at the legacy position in Northern Ireland will remain Outturn Available for all outages of their Outturn Availability Connection Assets.

An example of b is where a Generation Unit is moving from a temporary to a permanent connection and the generator will have Outturn Availability<sup>6</sup> of zero for their own connection works. However where work is being carried out to another Generation Unit (with a different Connection Point but a shared Outturn Availability Connection Asset) then Outturn Availability will equal that of the Generation Unit's Availability declared as per the Grid Code.

4. The "Guide to Transmission Equipment Maintenance" document will define what constitutes scheduled annual maintenance of the Outturn Availability Connection Asset with standard lead times and frequencies of maintenance in Ireland and will be published on the EirGrid website. SONI will facilitate the publishing of a link to a similar document on the Northern Ireland Electricity Networks (NIE Networks) website related to the standard lead times and frequencies of maintenance in Northern Ireland.
5. Designated days for TSO scheduled annual maintenance do not need to be consecutive to count towards the total of 5 calendar days.
6. A portion of a day of scheduled annual maintenance will count as one day, for example 3.5 days will be counted as 4 days.
7. Designated days are those aligned (where possible) with the Committed/Final Outage Programmes<sup>7</sup> before the outage commences. For five days of scheduled annual maintenance works, the Generation Unit will declare Outturn Availability of zero. For other days of scheduled annual maintenance (in the same calendar year) the Generation Unit will be deemed to be Outturn Available.
8. A Generation Unit on its own outage will not be deemed Outturn Available by default, as Availability shall be declared as per the relevant Grid Code.
9. Scheduled annual maintenance days will count towards the five designated days. Unscheduled outages such as forced outages on the Generation Unit's Outturn Availability Connection Asset will not count towards the five days and the affected Generation Unit will declare their Availability as per the Grid Code.
10. Changes to designated days
  - a. Generation Unit initiated outage change request: Should a Generation Unit subsequent to the assignment of designated days for scheduled annual maintenance change their own outage dates, the TSO (in consultation with the TAO) will make reasonable endeavours to realign the scheduled annual maintenance outage. However if this is not possible then the scheduled annual maintenance works will proceed as originally planned and the Generation Unit will not be Outturn Available for the first five days of scheduled annual maintenance works.

---

<sup>6</sup> Outturn Availability is defined for the purposes of this interpretation of SEM-15-071 as the set of Availability data for the relevant Generation Unit as declared under the relevant Grid Code and submitted by the relevant TSO to SEM after the end of the Trading Day.

<sup>7</sup> Committed Outage Programme and Final Outage Programme contain Generation Unit outages only and are published each September for the following calendar year. Committed Outage Programme and Final Outage Programme are as defined in the EirGrid and SONI Grid Codes respectively.

- b. TSO or TAO initiated outage change: The TSO or TAO may, subsequent to the assignment of designated days for scheduled annual maintenance, need to change the proposed dates of the scheduled annual maintenance. Although the TSO will attempt to align annual maintenance of OACA(s) with the Generation Unit's own outage, where alignment is not possible the TSO will endeavour to find a mutually acceptable date. For the avoidance of doubt during the rescheduled designated days the Generator Unit will not be Outturn Available. As with all changes to scheduled designated days, this will be recorded in the ex-post report.
11. Each TSO will schedule an ex-ante forum and an ex-post forum in quarter one of a calendar year.
  12. Where the TSO requires additional maintenance outages that are not considered in the "Guide to Transmission Equipment Maintenance" document, the TSO will endeavour to coordinate these outages with the Generation Unit's own outages planned and agreed in the Committed/Final Outage Programmes for any given year. Where it is not possible for the TSO to align these additional outages with the Generation Unit's own outage(s), the Generation Unit will remain Outturn Available.

## **1. Background**

The TSOs are obligated under the Trading and Settlement Code to provide a record of a Generation Unit's Outturn Availability to the Single Electricity Market (SEM) for market scheduling, pricing and settlement purposes. Outturn Availability is the name assigned in SEM to the set of availability data received by the SEM systems from the TSO's systems following the end of the relevant day. Outturn Availability data is used to develop the availability profile of each Generation Unit in SEM and consequently affects the commercial position of the Generation Unit, as it sets the upper limit on what the relevant Generation Unit can be scheduled to in SEM.

On 1 February 2013, the TSOs published a consultation paper in order to put in place a transparent and non-discriminatory set of principles that can be used by the TSOs in the determination of Outturn Availability for all Generator Units. The consultation paper sought the opinion of all parties on a range of options that the TSOs could apply to calculating Outturn Availability for situations other than when the Generation Unit is unavailable for technical reasons associated with the unit or its auxiliary plant.

A minded to decision paper was subsequently developed by the Utility Regulator Northern Ireland and the Commission for Energy Regulation (the Regulatory Authorities or RAs), which outlined their minded to decision on the calculation of Outturn Availability in the SEM.

On 29 September 2015, the SEMC published its decision paper SEM-15-071 on the "Process for the Calculation of Outturn Availability". In response to this paper the TSOs set out in version 1 and 2 of this document how they are implementing this decision across the island of Ireland.

## **2. Application of the SEMC Decision**

The SEM-15-071 decision paper applies to both transmission and distribution connected CDGUs and Controllable WFPS which are disconnected as a direct result of a TSO outage of an Outturn Availability Connection Asset. The associated addendum published on 22 December 2015 provides clarity on the implementation date of the decision, and accordingly, the principles of the ruleset outlined in SEM-15-071 are applied from 1 January 2016.

## **3. Outturn Availability Connection Assets**

Outturn Availability Connection Asset(s), for the purposes of this interpretation of SEM-15-071, are defined as any equipment that is part of the Transmission System between and including the Connection Point and the busbar clamps at the Meshed Transmission Station for which the TSO schedules outages.

## **4. Capital Outages**

If a Generation Unit is on a temporary connection and that Generation Unit is disconnected as a direct result of works to make that Generation Unit's own connection permanent, then the Generation Unit will not be Outturn Available.

Where work is being carried out that is related to an existing Generation Unit, the Generation Unit will not be Outturn Available. However, where work is being carried out on another Generation Unit that has a separate connection point but a shared portion of the Outturn Availability Connection Asset, then the Generation Unit disconnected for works not related to that Generation Unit will remain Outturn Available.

Where an outage is related to the connection of a subsequent phase (for example of a wind farm) with a shared Connection Point, then all the disconnected phases will not be Outturn Available for the duration of the outage.

## **5. Annual Maintenance Outages**

In considering maintenance, SEM-15-071 addresses CDGUs and Controllable WFPS (both distribution and transmission) which are disconnected as a direct result of a TSO planned transmission outage for scheduled annual maintenance of up to five calendar days on the Outturn Availability Connection Asset. The role of the TSOs is to schedule the relevant annual maintenance transmission outages and to track the five designated days.

## **6. Definition of Annual Maintenance**

EirGrid will produce a list of scheduled annual maintenance items (as well as estimated durations and frequency for the same) which will be included in the “Guide to Transmission Equipment Maintenance” document, to be published on the EirGrid website. As all maintenance is the responsibility of the Transmission Owner (NIE Networks) in Northern Ireland, SONI will facilitate the publishing of a link to such a document on the NIE Networks website.

## **7. The Five Designated Days of Annual Maintenance**

Designated days for annual maintenance do not need to be consecutive to count towards the total of five days, and will be calculated on a calendar day basis. For administrative purposes any portion of a day of annual maintenance will count as one day. For example three and a half days of annual maintenance work will be counted as four days.

### **Scheduling Designated Days**

Where a Generation Unit has no outage dates in the Committed/Final Outage Programmes, then the designated days will be determined by the TSO.

Where a Generation Unit has an outage in the Committed/Final Outage Programmes then the TSO will attempt to align annual maintenance with a Generation Unit’s own outage wherever possible. It is very important that the generators correctly populate the “Generator Outage Detail Form” to highlight if there are any restrictions on when EirGrid can schedule maintenance works. However, to allow this alignment, the Generation Unit’s own outage works must not interfere with or prevent the annual



maintenance from taking place. When aligning with a Generation Unit's own outage, standard TAO working days will be scheduled to complete the annual maintenance where sufficient days are available.

The five designated days are scheduled by the TSO before the scheduled annual maintenance works commence. The TSO will apply the principle that the first five days of scheduled annual maintenance works will be deemed designated days (provided that the Outturn Availability Connection Assets are available for maintenance) and the Generation Unit will be required to declare Availability as zero during each designated day, commencing from the start of the outage on the first designated day. Upon completion of the scheduled annual maintenance (or at the end of the designated days, whichever comes first), the Generation Unit will declare their Availability as per the relevant Grid Code. An exception will be applied where the annual maintenance outage is scheduled to commence ahead of the Generation Unit's own outage and will last longer than 5 calendar days. In this scenario, the designated days will be aligned with the Generation Unit's own outage where possible, unless annual maintenance cannot be carried out due to the Generator Unit's own works which will require the scheduled annual maintenance and the designated days to be realigned accordingly. In the event that the Generation Unit's outage is less than five days then the remaining designated days will be assigned as per the normal principle (i.e. from the start of the outage).

#### **Generation Unit Initiated Outage Change Request**

A Generation Unit may subsequently apply to the TSO to change their outage dates. Typically, the scheduled annual maintenance works will already be aligned with the Generation Unit's previous outage dates. In this instance, the TSO will apply reasonable endeavors to realign the scheduled annual maintenance outage. However, if this is not possible then the scheduled annual maintenance works will proceed as originally planned and the Generation Unit will not be Outturn Available for the first five days.

For the avoidance of doubt, when a maintenance outage is scheduled but cannot actually be completed on the day in question. This may for example be due to a Generation Unit's own works or a lack of available personnel on the Generation Unit's side (e.g. for telemess), then the Generation Unit will not be deemed Outturn Available for the rescheduled dates, i.e. the designated day will be rescheduled to align with the rescheduled annual maintenance.

#### **TSO or TAO Initiated Outage Change**

The TSO or TAO may, subsequent to the assignment of designated days for scheduled annual maintenance, change the proposed dates and/or scope of the scheduled annual maintenance. Although the TSO will attempt to align annual maintenance of OACA(s) with the Generation Unit's own outage, where alignment is not possible the TSO will endeavour to find a mutually acceptable date. For the avoidance of doubt during the rescheduled designated days the Generator Unit will not be Outturn Available. As with all changes to scheduled designated days, this will be recorded in the ex-post report.

## **8. Other Relevant Transmission Outages**

For forced outages and proximity outages, in so far as they impact on the Generation Unit, the Generation Unit should remain Outturn Available.

Transmission outages not covered by this are works carried out at the Generation Unit's request or work specifically to accommodate the Generation Unit – e.g. work to increase capacity or work to transition a Generation Unit from a temporary connection to a permanent connection. For these outages, the Generation Unit will not be Outturn Available. For the avoidance of doubt, capital works do not contribute to the 5 designated days for the relevant Generation Unit unless annual maintenance is scheduled to overlap. For the duration of these works, any other unrelated Generation Unit with a shared portion of an Outturn Availability Connection Asset but a different Connection Point will remain Outturn Available.

## **9. The Fora**

The ex-ante and the ex-post fora will be held in Quarter One (Q1) of each calendar year. The fora will act as an aid to the outage planning process already in place. Subsequent to the ex-ante forum, separate outage plans will be published by both EirGrid and SONI. A separate forum will be held by EirGrid and SONI for both the ex-post and the ex-ante planning. For the ex-post fora each TSO will publish a summary report of the outage schedule at the end of the outage season. The summary will compare the estimated time for each maintenance task against the time actually needed for each task. The summary will also track the number of outage change requests received by the TSO from the relevant Generation Unit and the number of outage change requests sent by the TSO to the relevant Generation Unit for designated days or annual maintenance on Outturn Availability Connection Assets. The ex-ante outage plans and the ex-post summaries will be sent to the RAs for review. Generation Outage Planning related material is detailed on the EirGrid/SONI websites with the appropriate forms and contact information. The fora will be an additional avenue for positive engagement between parties in addition to the current outage planning process which include for example one to one meetings between TSO Generation customers and the TSOs to discuss the outage plans. The scope of the fora includes outage of Outturn Availability Connection Assets only. Other outages and the scheduling of the same fall outside of the scope of the fora.

## **10. Outturn Availability Declarations**

A Generation Unit will be informed by the TSO in advance where a transmission outage affects the Generation Unit's Outturn Availability. The DSO will be informed in advance of transmission outages directly impacting the distribution system. Where a distribution connected Generation Unit is impacted by a TSO scheduled transmission outage this Generation Unit will be informed by the DSO.

CDGUs will declare the appropriate Availability to reflect their Outturn Availability in the All-Island Electronic Dispatch Instruction Logger (EDIL).

## **11. Application of the decision to both Transmission and Distribution Connected Facilities**

The SEM-15-071 decision paper states that the decision applies to both transmission and distribution connected generators. The RAs confirmed in correspondence with the TSOs on 27 January 2016 that *“The SEMC decision paper does not apply to planned outages on the Distribution system. However, as noted by the TSOs, all generators within their remit (those controllable or centrally dispatched) be they transmission or distribution connected, will be treated in a consistent manner, in terms of the calculation of outturn availability, where impacted by transmission system outages.”*

Outages on the distribution system are not related to the decision paper, and as such any distribution connected CDGUs or Controllable WFPSs shall declare unavailable when disconnected due to a DSO planned outage.

## Appendix 1: Example to demonstrate Annual Maintenance Outages

This appendix sets out examples to demonstrate the implementation of the Outturn Availability decision where one or more Transmission Stations are tailed from a meshed Transmission Station and a distribution connected customer is connected in turn to a tailed Transmission Station.

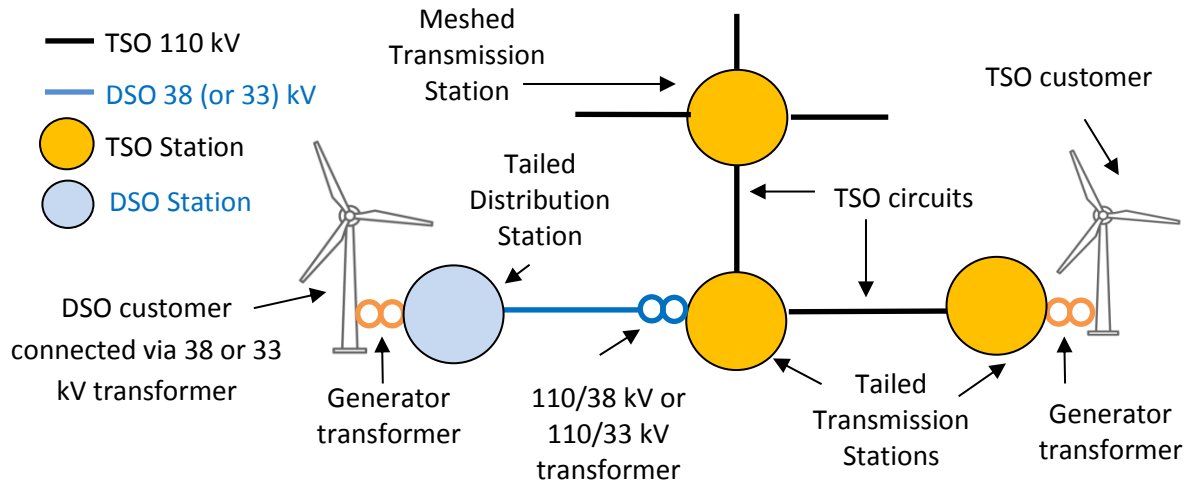

Figure 1: Normal configuration: Outturn Availability Connection Assets in place. Both windfarms are Outturn Available.

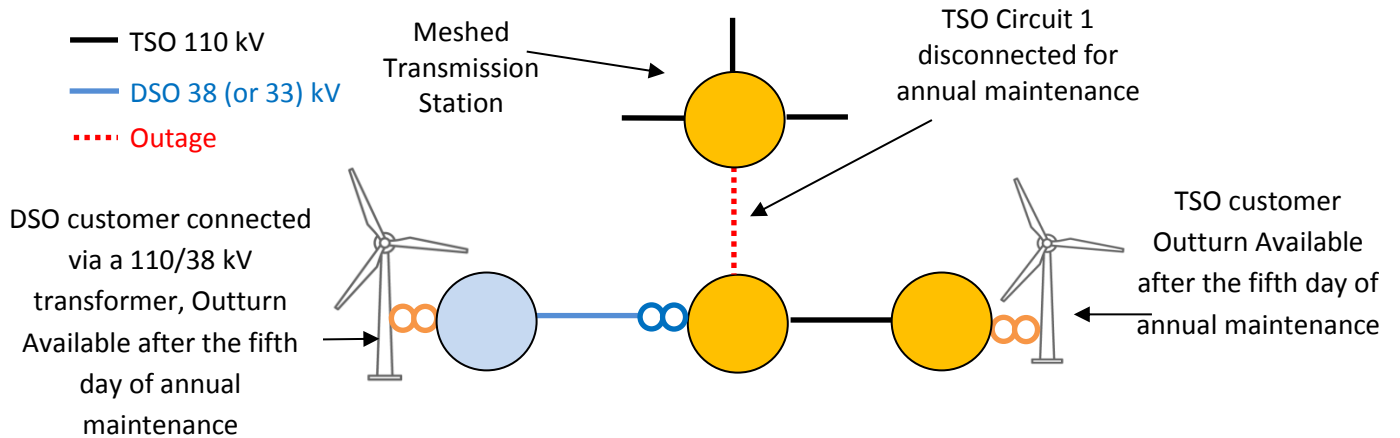

Figure 2: Shared Outturn Availability Connection Assets of both facilities disconnected for Annual Maintenance. Both facilities are not Outturn Available for the first 5 days.

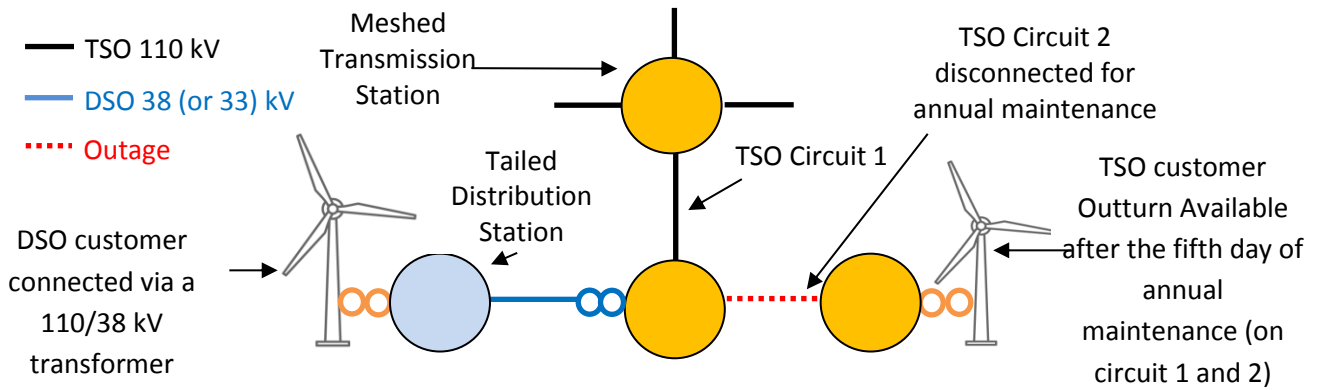

Figure 3: Outturn Availability Connection Asset of TSO Generation Unit disconnected for Annual Maintenance. TSO connected Generation Unit Outturn Available after the 5th day (i.e. of the cumulative total of the outage works on Circuit 1 & 2). DSO Generation Unit remains fully Outturn Available during works on Circuit 2.

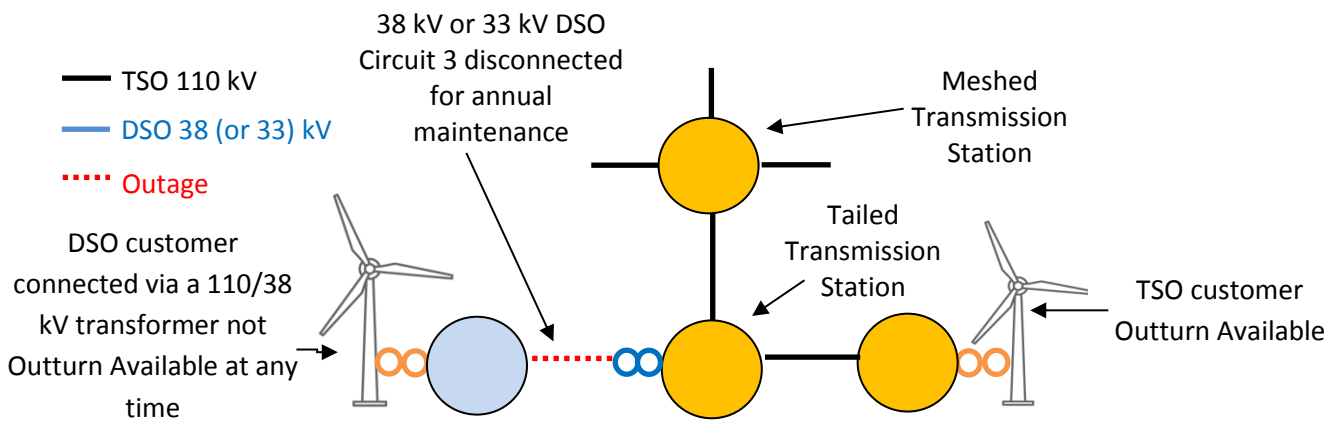

Figure 4: Outturn Availability Connection Asset of DSO Generation Unit not disconnected for TSO scheduled Annual Maintenance. The DSO connected Generation Unit is disconnected for distribution system works and is not Outturn Available at any time. TSO Generation Unit remains fully Outturn Available.

## Appendix 2: Example to demonstrate Annual Maintenance Outages

This appendix sets out examples to demonstrate the implementation of the Outturn Availability decision where one or more Distribution Stations are tailed from a meshed Transmission Station.

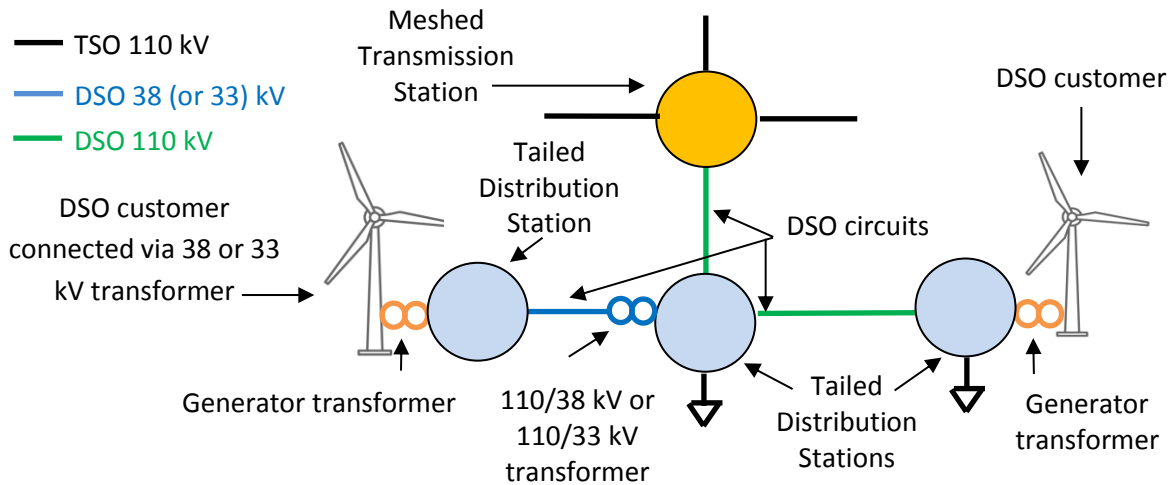

Figure 5: Normal configuration: There are no Outturn Availability Connection assets as both windfarms are connected to the meshed transmission system by distribution equipment, with the DSO connection to the meshed transmission system in place both wind farms are Outturn Available.

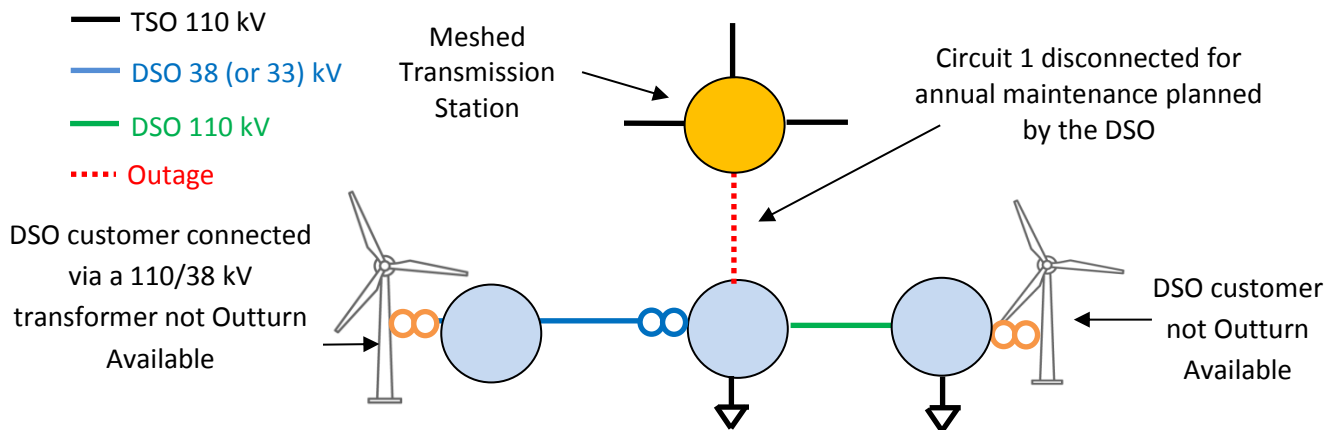

Figure 6: DSO Connection Assets of both facilities disconnected for Annual Maintenance planned by the DSO. Both facilities are not Outturn Available at any time.

## Appendix 3: Example to demonstrate Transmission Outages for Capital Works

This appendix sets out an example to demonstrate the implementation of the Outturn Availability decision during capital works associated with a Generation Unit on a temporary connection.

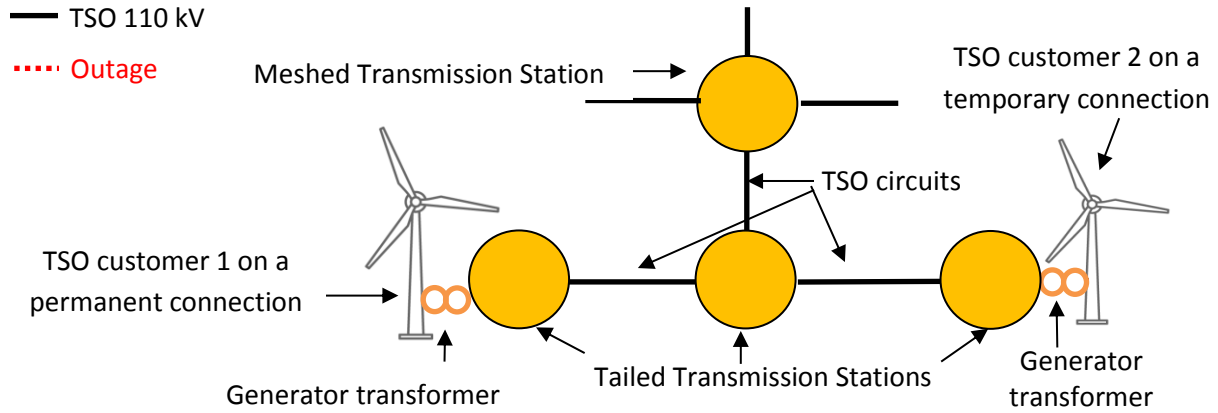

Figure 7: Normal configuration: Customer 1 on a permanent connection, Customer 2 on a on a temporary connection.

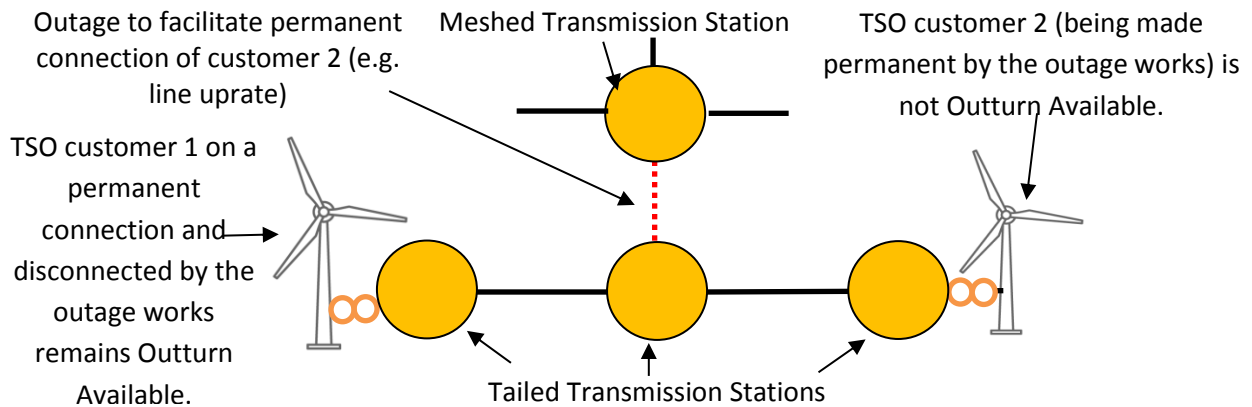

Figure 8: Line up-rate required to facilitate the permanent connection of customer 2. Customer 1 Outturn Available, customer 2 not Outturn Available.

## Appendix 4: Example to demonstrate a Generation Unit's own Outage

This appendix sets out an example to demonstrate the implementation of the Outturn Availability decision during a Generation Unit's own outage.

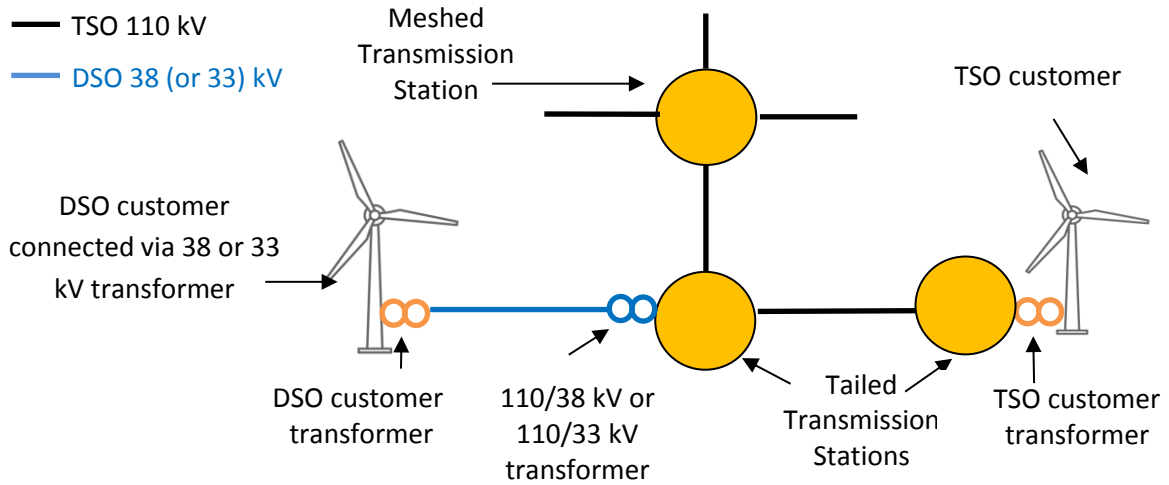

Figure 9: Normal configuration: Outturn Availability Connection Assets in place. Both windfarms are Outturn Available.

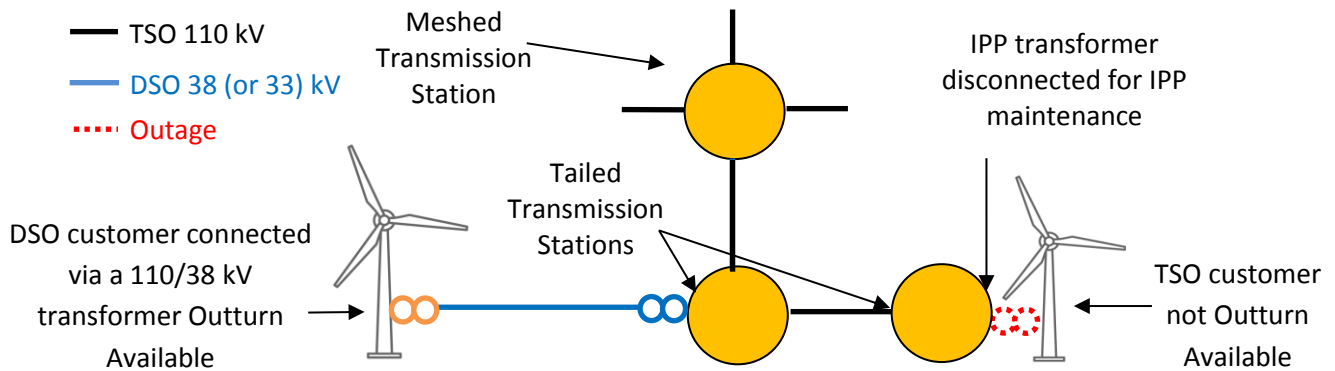

Figure 10: Outturn Availability Connection Assets of both facilities in-place. However a TSO customer's own assets are disconnected for maintenance, the TSO customer is not Outturn Available. The DSO customer remains unaffected.



## Appendix 5: Example to demonstrate Other Relevant Transmission Outages

This appendix sets out an example to demonstrate the implementation of the Outturn Availability decision during a transmission outage associated with one Generation Unit.

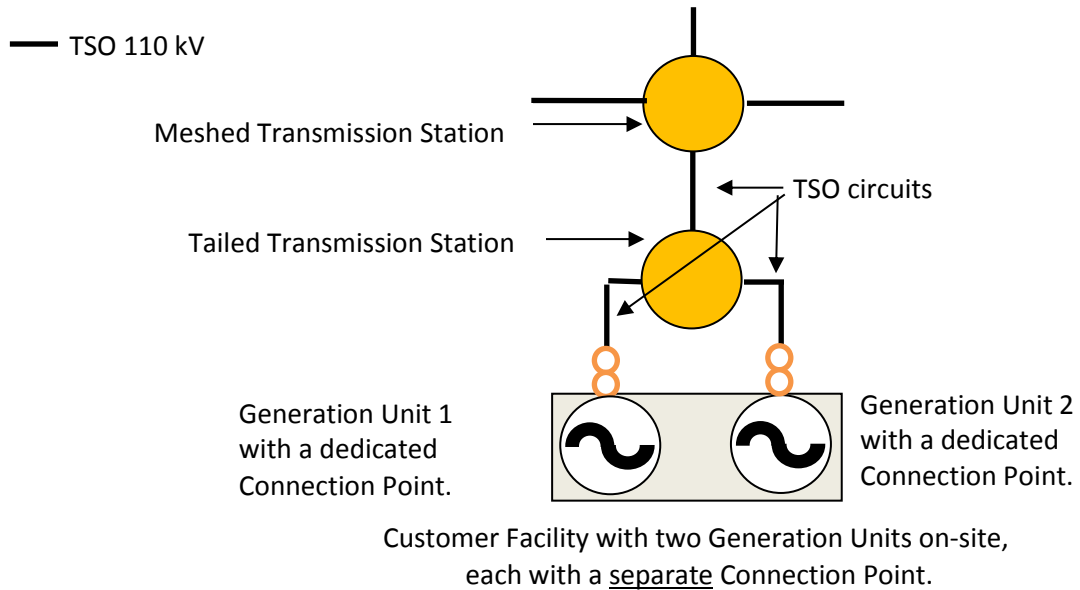

Figure 11: Normal Configuration: Unit 1 and Unit 2 each have separate Connection Points.

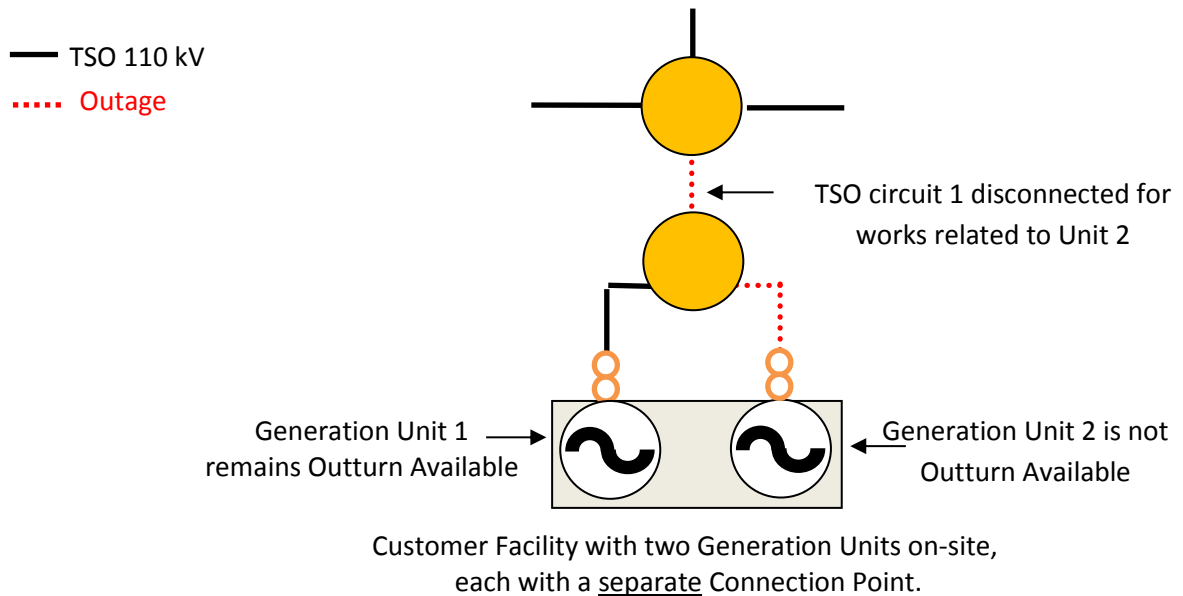

Figure 12: Unit 1 and Unit 2 disconnected for works related to Unit 2. Unit 1 remains Outturn Available while Unit 2 is not Outturn Available.

## Appendix 6: Examples of allocation of Designated Days

Table 1: Maintenance < Generator Outage

	We	Th	Fr	Sa	Su	Mo	Tu	We	Th	Fr
Generator's own Outage										
OACA Maintenance										
Outturn Availability of Generator	0	0	0	0	0	0				
Accumulation of Designated Days	1/5	2/5	3/5							

Table 2: Maintenance < Generator Outage

	We	Th	Fr	Sa	Su	Mo	Tu	We	Th	Fr
Generator's own Outage										
OACA Maintenance										
Outturn Availability of Generator	0	0	0	0	0	0	0	0		
Accumulation of Designated Days	1/5	2/5	3/5			4/5	5/5			

Table 3: Maintenance < Generator Outage, Grid Connected Transformer needed in service by generator on the first day of Generator Outage

	We	Th	Fr	Sa	Su	Mo	Tu	We	Th	Fr
Generator's own Outage										
OACA Maintenance										
Outturn Availability of Generator	0	0	0	0	0	0	0	0		
Accumulation of Designated Days		1/5	2/5			3/5	4/5	5/5		

Table 4: Maintenance > Generator Outage, Generator available after 5<sup>th</sup> day of OACA maintenance.

	We	Th	Fr	Sa	Su	Mo	Tu	We	Th	Fr
Generator's own Outage										
OACA Maintenance										
Outturn Availability of Generator	0	0	0	0	0	A	A	A		
Accumulation of Designated Days	1/5	2/5	3/5	4/5	5/5					

**Table 5: Maintenance > Generator Outage**

	We	Th	Fr	Sa	Su	Mo	Tu	We	Th	Fr
Generator's own Outage										
OACA Maintenance										
Outturn Availability of Generator	0	0	A	0	0	0	A	A		
Accumulation of Designated Days	4/5	5/5		1/5	2/5	3/5				

**Table 6: Multiple maintenance outages required at different times during the same calendar year**

	We	Th	Fr	Sa	Su		Th	Fr
Generator's own Outage								
OACA Maintenance						.....		
Outturn Availability of Generator	0	0	0	0			0	A
Accumulation of Designated Days	1/5	2/5	3/5	4/5			5/5	

**Table 7: Maintenance and Capital works (Transmission Capital works)**

	We	Th	Fr	Sa	Su	Mo	Tu	We	Th	Fr
Generator's own Outage										
OACA Maintenance										
Tx. Capex (Not associated)										
Outturn Availability of Generator	0	0	0	0	0	A	A	A	A	
Accumulation of Designated Days	1/5	2/5	3/5	4/5	5/5					

**Table 8: Associated Capital Works (Transmission Capital works)**

	We	Th	Fr	Sa	Su	Mo	Tu	We	Th	Fr
Generator's own Outage										
OACA Maintenance										
Tx. Capex (Associated)										
Outturn Availability of Generator	0	0	0	0	0	0	0	0	0	
Accumulation of Designated Days	1/5	2/5	3/5	4/5	5/5					

## Appendix 7: Outturn Availability “Quick Guide” Decision Matrix

Table 2: “Quick Guide” decision matrix for TSO planned transmission outages

CDGU or Controllable WFPS disconnected for a TSO transmission outage	Generation Unit on own outage	Annual Maintenance of the Generation Unit's Outturn Availability Connection Assets ≤ 5 calendar days	If capital works, are the works related to the Generation Unit?	Is the disconnected Generation Unit Outturn Available?
No	N/A			No
Yes	Yes	N/A		No
	No	Yes	N/A	No
		No (e.g. Capital works, forced outages, proximity outage or annual maintenance works after the 5 <sup>th</sup> calendar day)	Yes	No
			No (or N/A)	Yes

Note that Generators connected at the “legacy” position in Northern Ireland are deemed Outturn Available if there is an outage of the Outturn Availability Connection Assets in all cases (i.e. for fault repair or maintenance).